

# 1. QR CODE



[electrolux.com/manual/microplasticfilter](http://electrolux.com/manual/microplasticfilter)



**UK IE** Read instructions before installation for important safety warnings and tips.  
Scan the QR code to access full user manual in local language.

**BG** За важни предупреждения и съвети за безопасност, прочетете инструкциите преди инсталирането.  
Сканирайте QR кода, за да получите достъп до пълното ръководство за потребителя на местния език.

**CZ** Před instalací si přečtěte pokyny, které obsahují důležitá bezpečností varování a tipy.  
Oskenováním QR kódu získáte přístup ke kompletní uživatelské příručce v místním jazyce.

**DE AT BE CH** Lesen Sie vor der Installation die Anleitung durch und machen Sie sich mit wichtigen Warnhinweisen und Tipps vertraut.  
Scannen Sie den QR-Code, um auf das vollständige Benutzerhandbuch in lokaler Sprache zuzugreifen.

**DK** Læs anvisningerne før installation for vigtige sikkerhedsadvarsler og tips.  
Scan QR-koden for at få adgang til hele brugsanvisningen på dit lokale sprog.

**NO** Les instruksjonene før montering for viktige sikkerhetsadvarsler og tips.  
Skann QR-koden for å få tilgang til hele brukerhåndboken på det lokale språket.

**ES** Lea las instrucciones antes de la instalación para ver consejos y conocer advertencias de seguridad importantes.  
Escanee el código QR para acceder al manual de usuario completo en local.

**ET** Lugege enne paigaldust ohutusjuhustest olulisi hoiatusi ohutuse kohta ja nõuandeid.  
Kohalikus keeles kasutusjuhendile juurdepääsuks skaneerige QR-kood.

**FI** Lue ohjeiden sisältämät tärkeät turvallisuusvaroitukset ja -vinkit ennen asennusta.  
Pääset lukemaan käyttöopasta kokonaisuudessaan paikallisella kielellä lukemalla QR-koodin.

**FR BE LU CH** Lisez les instructions avant l'installation pour prendre connaissance des avertissements et des conseils de sécurité importants.  
Scannez le code QR pour accéder au manuel d'utilisation complet dans votre langue.

**EL** Διαβάστε τις οδηγίες πριν από την εγκατάσταση για σημαντικές προειδοποιήσεις και συμβουλές ασφαλείας.  
Σαρώστε τον κωδικό QR για να έχετε πρόσβαση σε ολόκληρο το εγχειρίδιο χρήση στην τοπική γλώσσα.

**HU** Telepítés előtt olvassa el az utasításokat a fontos biztonsági figyelmeztetések és tippek megismeréséhez.  
Olvassa be a QR-kódot a teljes felhasználói kézikönyv helyi nyelven történő eléréséhez.

**LV** Pirms uzstādīšanas izlasiet norādes par svarīgiem drošības brīdinājumiem un ieteikumiem.  
Noskenējiet QR kodu, lai piekļūtu pilnai lietotāja rokasgrāmatai vietējā valodā.

**LT** Prieš montuodami perskaitykite instrukciją, kurioje pateikti svarbūs saugos įspėjimai ir patarimai.  
Nuskaitykite QR kodą ir gaukite visą naudotojo vadovą vietine kalba.

**NL BE** Lees de instructies voor de installatie voor belangrijke veiligheidsaanschuwingen en tips.  
Scan de QR-code om toegang te krijgen tot de volledige gebruikershandleiding in de lokale taal.

**PL** Przed instalacją należy zapoznać się z instrukcją, w której znajdują się ważne wskazówki i ostrzeżenia dotyczące bezpieczeństwa.  
Aby uzyskać dostęp do pełnej instrukcji obsługi w miejscowym języku, należy zeskanować kod QR.

**PT** Leia as instruções antes da instalação para ver avisos de segurança e sugestões importantes.  
Efetue a leitura do código QR para aceder ao manual do utilizador completo no idioma local.

**RO** Citiți instrucțiunile înainte de instalare pentru avertismente și recomandări importante privind siguranța.  
Scanați codul QR pentru a accesa manualul complet al utilizatorului în limba locală.

**RU** Перед установкой и началом использования ознакомьтесь с важными указаниями по технике безопасности. Вы всегда можете найти и загрузить инструкцию по эксплуатации на русском языке отсканировав QR код, напечатанный на стр.2.

**SE** Läs anvisningarna före installationen för viktiga säkerhetsvarningar och tips.  
Skanna QR-koden för att få åtkomst till hela användarhandboken på lokalt språk.

**SK** Pred inštaláciou si prečítajte pokyny pre dôležité bezpečnostné upozornenia a tipy.  
Naskenovaním QR kódu získate prístup k celému návodu na používanie v miestnom jazyku.

**SI** Pred namestitvijo preberite navodila za pomembna varnostna opozorila in nasvete.  
Skenirajte QR kodo za dostopanje do celotnih navodil za uporabo v lokalnem jeziku.

**TR** Önemli güvenlik uyarıları ve ipuçları için montaja başlamadan talimatları okuyun.  
Yerel dilde kapsamlı kullanıcı kılavuzuna ulaşmak için QR kodunu tarayın.

**UA** Прочитайте інструкції перед встановленням, щоб дізнатися про важливі попередження та поради щодо техніки безпеки.  
Відскануйте QR-код, щоб отримати доступ до повної інструкції з експлуатації місцевою мовою.

**IT** Leggi le istruzioni prima dell'installazione per importanti avvertenze e suggerimenti sulla sicurezza.  
Esegui la scansione del codice QR per accedere al manuale utente completo nella lingua locale.



## 2. ⚠ SAFETY INFORMATION

Before the installation and use of the product, read the supplied instructions carefully. The manufacturer is not responsible for any injuries or damage that are the result of incorrect installation or usage. Always keep the instructions in a safe and accessible location for future reference.

- This product is designed for filtering microplastic fibres released from textiles during the washing process and should not be used for other purpose.
- This product can be used by children aged from 8 years and above and persons with reduced physical, sensory or mental capabilities or lack of experience and knowledge if they have been given supervision or instruction concerning the use of the product in a safe way and understand the hazards involved. Children of less than 8 years of age and persons with very extensive and complex disabilities shall be kept away from the appliance unless continuously supervised.
- Do not let children play with the product. Keep all packaging away from children and dispose of it appropriately.
- Children shall not carry out cleaning and user maintenance of the product without supervision. Keep detergents away from children.
- This product is intended to be used in household and similar applications such as:
  - staff kitchen areas in shops, offices and other working environments;
  - farm houses;
  - by clients in hotels, motels, bed & breakfast and other residential type environments;
  - areas for communal use in blocks of flats or in laundrettes.
- Follow the installation instructions supplied with the product.

- Do not install or use a damaged product or drain hoses.
- Install the product in a safe and suitable place that meets installation requirements.
- Do not install the product above any electrical sockets, or above any devices located on the wall, or freestanding devices close by on the floor to avoid the risk of electric shock.
- Remove all the packaging.
- Make sure the pipes are fixed properly to avoid leaks, noise or damage.
- Ensure proper drain hose path between the appliance and the filter inlet to avoid blocking the drain flow.
- Fixing devices for the wall are not included owing to different wall materials. Use proper fixing devices suitable for the walls.
- Ensure that there are no visible water leaks during and after the first use of the product.
- Do not use high pressure water sprays and/or steam to clean the product.
- Always switch off and check that the machine is not running before accessing or cleaning the product.
- Clean the product with a moist cloth. Use only neutral detergents. Do not use abrasive products, abrasive cleaning pads, solvents or metal objects.
- Clean the cartridge regularly, once a week or when the red floater indicator is clearly visible.
- Do not reuse water from the filter. It may contain micro-plastic particles that are unfit for human and animal consumption.
- To repair the product contact the Authorised Service Centre. Use only original spare parts.
- This external accessory is compatible with Electrolux/AEG/Zanussi household washing machines.

### **Environmental concerns**

Recycle materials with the symbol . Put the packaging in relevant containers to recycle it.

## 3. INSTALLATION

### 3.1 Before Installation



**WARNING!**  
Refer to Safety chapters.



Visit [electrolux.com/getstarted/microplasticfilters](https://electrolux.com/getstarted/microplasticfilters) for the installation and usage videos.

#### 1. Select a proper location on the wall to install filter:

To avoid leakages over the washing machine, it is preferable to instal the filter on either side of your washing machine.

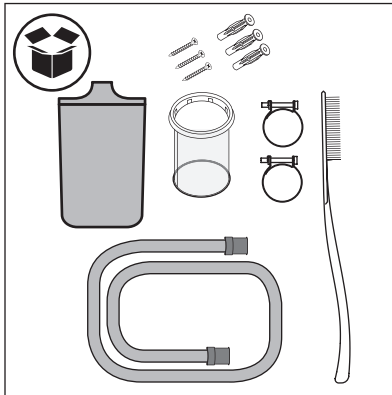
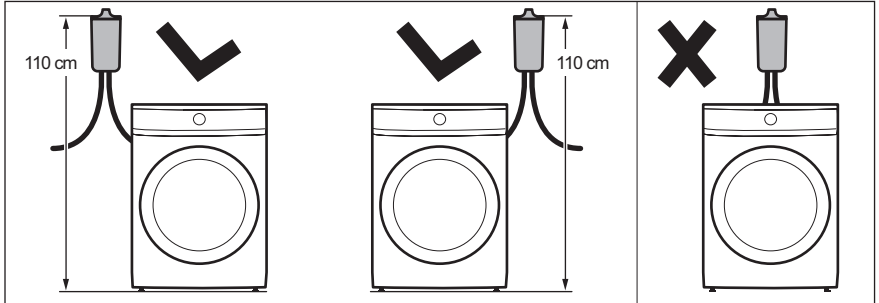

**2. Verify box content.**

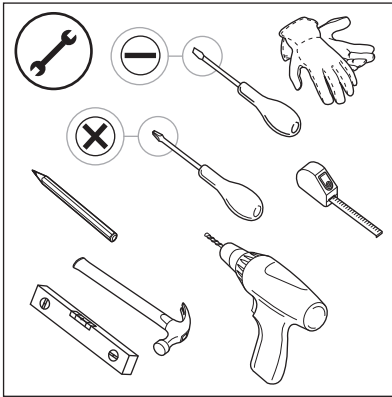

**3. Prepare necessary tools for the installation.**

### **3.2 Installing the accessory**

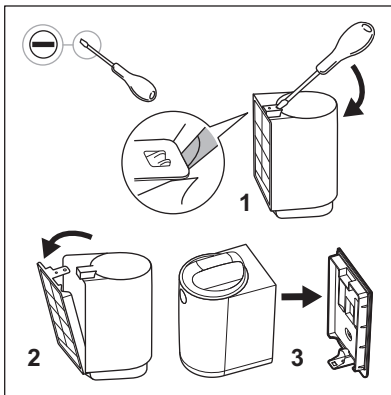

**1. Remove the filter from packaging box and remove the wall support with the help of a flat screwdriver.**

**2. The position of your filter needs to follow these listed points (a and b):**

a. Position the wall support at the correct height, measuring 110 cm\* from top of the wall support to the floor (or pedestal if present). \***Tolerance admitted in filter height position is +/-5 cm.**

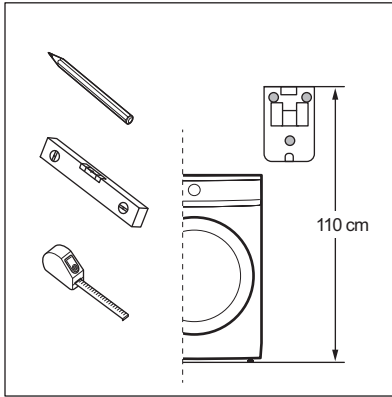

Check where your point of drainage is before positioning the wall support. Filter is equipped with one drainage pipe with length of 100 cm.



Make sure there is enough space above your filter before positioning the wall support. Be sure to leave adequate free space above the filter in order to remove and re-insert the cartridge. See minimum dimensions reference in Appendix 1 (Front Loader) and Appendix 2 (Top Loader).

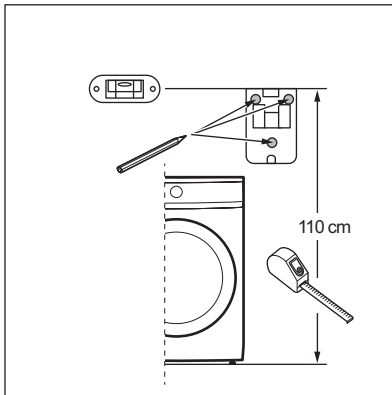

b. Use a level to check that the 3 drilling punches are level and well-aligned before drilling.



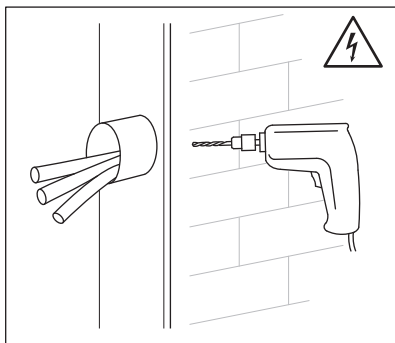

### 3. Drill the holes into the wall and place the anchors.

#### **WARNING!**

Before drilling in the wall, make sure no water pipes or electrical wires are behind. It is recommended to use a  $\phi$  6mm drill bit. The filter package includes three dedicated screws and plastic anchors to properly and securely install the filter. The provided fixation system is designed for installation on a brick wall. In case of doubt, refer to the technician.

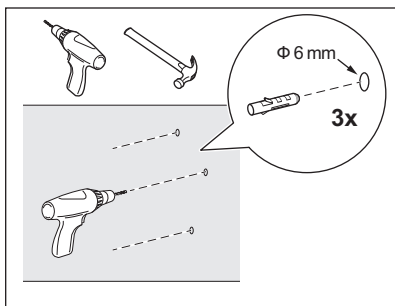

#### **WARNING!**

If your wall is made of different material than brick, use the proper anchors and screws designed for that material.

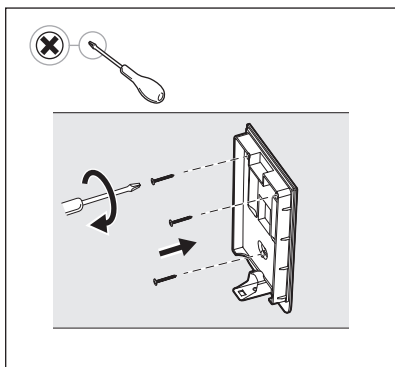

### 4. Attach the wall support with the screws and plastic anchors provided, making sure it is straight and securely affixed to the wall.

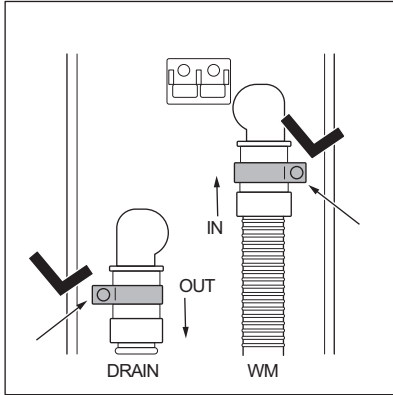

### 5. Take the hoses, the collars and the filter body.

Insert the collars on the hoses and connect pipes to the filter body following **IN/OUT** indications present on the back of the filter body:

**IN:** hose which comes from the WM,

**OUT:** hose (present in the filter package) which goes to the drain.

#### **WARNING!**

Before connecting the drainage hose to the external filter, be sure that the washing machine is turned OFF and unplugged from the electrical socket.



### 6. Tighten the collars using the screwdriver.

Follow these instructions exactly in order to position the collars to ensure a complete connection.

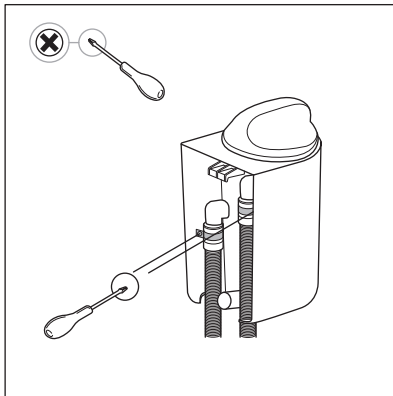

When using the screwdriver, be careful not to damage the filter body or the hoses.

7. Following the movement shown in the picture, when attaching the filter body to the wall support, you will hear the a "click" as the body is correctly attached to the wall support.

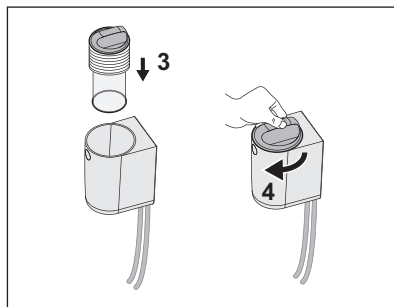
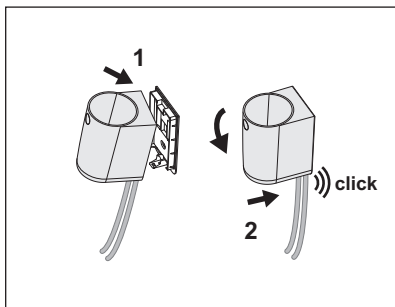

- i** Before proceeding to the next topic Daily use & care and cleaning, start the short washing programme and follow it until the end. Be sure that no leakages appear from the filter and its connections. In case of water leakage, proceed as described in paragraph 8. Detach the filter assembly from the wall support and tighten the collars. To reinstall the filter, repeat the steps in paragraph 7.

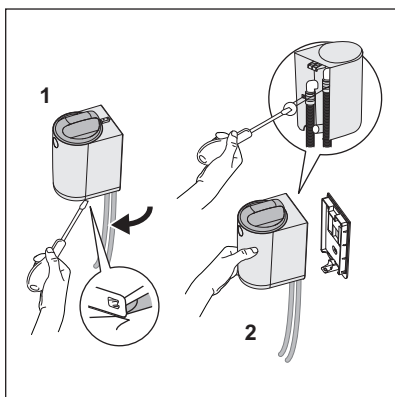

**8.** If any water appears during first cycle, stop the programme immediately. Turn the washing machine OFF and unplug it from the electrical socket. Before proceeding with the detaching procedure, check that the filter cover stays in the locked position in order to avoid any water leakage while tightening the collars.

Detach entire filter from the wall support:

1. Un-clip the filter from the wall support using the screwdriver,
2. Hold the filter in your hand to tighten the collar with the screwdriver.

Repeat the steps in paragraph 7 to install filter.

## 4. DAILY USE & CARE AND CLEANING

**!** **WARNING!**  
Refer to Safety chapters.

**!** **WARNING!**  
Always switch off and check that the machine is not running before accessing or cleaning the filter.

**i** Filter cartridge is made with thin Polyamide net in order to catch the microfibrils released from the laundry washing process.

**i** After some washing cycles the filter cartridge will clog and must be cleaned

**i** Number of cycles before the activation of floater will depend on several factors (kind of textile, drum size, most used programs, type of cycles and duration, laundry load, detergent, degree of soiling, etc.).

 Clean the cartridge regularly, once a week or when the red floater indicator is clearly visible.

 When the filter is clogged, the red floater located inside the cover becomes visible, alerting the user that the cartridge needs to be cleaned, as shown in the next picture.



**WARNING!**

Do not reuse water from the filter. It may contain micro-plastic particles that are unfit for human and animal consumption.

#### 4.1 "Red alarm" condition

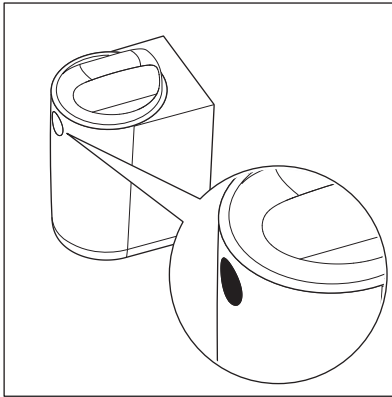

Red floater indicates that the filter is full and needs to be cleaned.

In "**red alarm**" mode (when the floater is activated) the filter will not stop the washing cycle, but it will work in a bypass mode and will not filter anymore. Therefore, to ensure optimal performance, it is recommended cleaning the cartridge as soon as possible to avoid leaving the filter in "**red alarm**" mode.



**WARNING!**

For several reasons the washing machine could show possible warnings, linked to draining issues, such as **E20-E21**. If this warning appears, first check the new external filter and clean it. If the error remains, check also the filter of your washing machine and clean it, if it is accessible.

Stopping the washing machine (error) is a safety feature of the machine to avoid long draining times and to not damage the machine. After the filter cartridge has been cleaned, normal operation can be resumed.

## 4.2 Care and Cleaning

### Cleaning the filter and microfibres disposal.

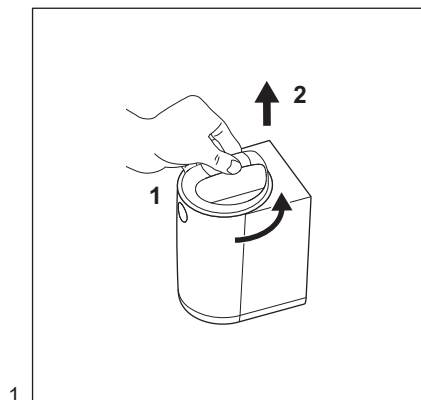

1.

To open the filter, refer to the movements in Picture 1 and 2:

1. Rotate the cover counter clockwise from lock symbol to unlock symbol (available on front of filter as shown in picture 2),
2. Lift up the cover.

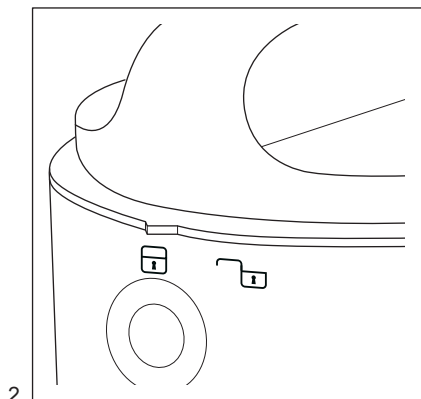

2.

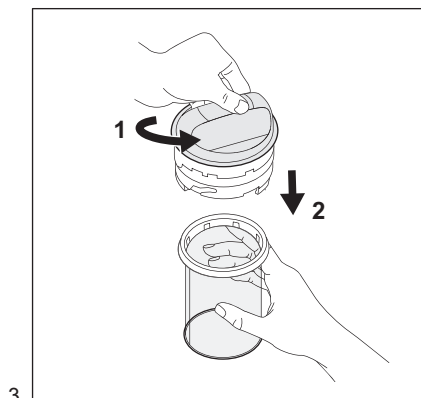

3.

To detach the cartridge, refer to the movements in Picture 3:

1. Hold the cover in your hand, then with the other hand rotate the cartridge counterclockwise from lock symbol to unlock symbol (see picture 4 and 5).
2. Pull down the cartridge.

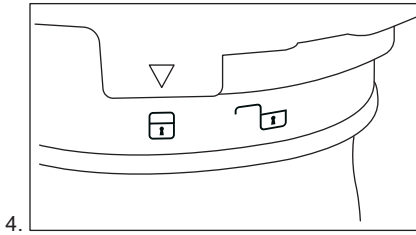

4.

To Lock/Unlock the cartridge, refer to Picture 4 and 5:

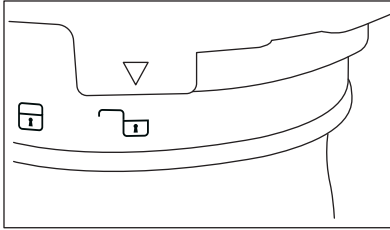

5.

Lock (picture 4) / Unlock (picture 5).



To clean the cartridge and dispose of its contents, refer to Picture 6, 7, 8 and 9.



6.

If the cartridge is fully clogged, it may be full of dirty water.

In order to be prepared for the cleaning operation, it is suggested to use any pot or small plastic container; this could help the operation and prevents the environment around from getting wet.

To remove the remaining water inside the cartridge, empty it out inside a pot or a container by holding the assembly cover and shaking it. The water flows out. In case some water still remains, proceed with the next step.

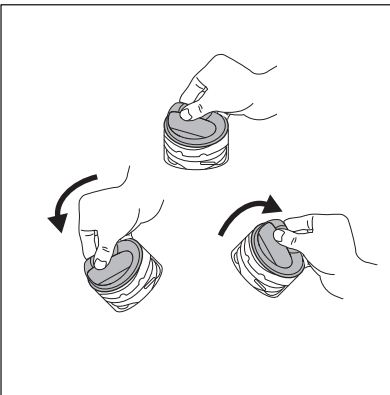

7.



To reset filter, refer to Picture 7.

Before placing the cover back on the cartridge, reset the floater by removing water inside the cover. Hold the cover, rotate it (see picture 7) and drain all the water into a plastic container. The floater is no longer visible when the cover is placed on the filter.



A noise could be heard but this is normal behaviour since inside the cover there is a mass valve.

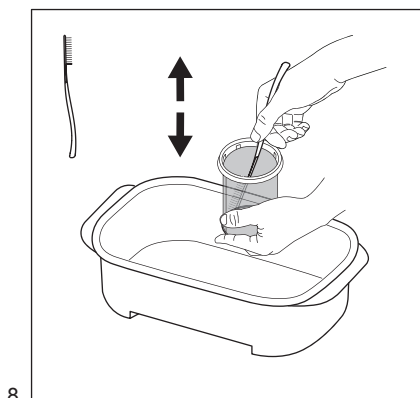

Holding the cartridge inside the container, use the brush-spatula tool available in the filter box. With up/down brush movement remove as much as possible the fibres attached to the cartridge net to help the evacuation of water.



Dispose of waste from the filter into the general dry waste.

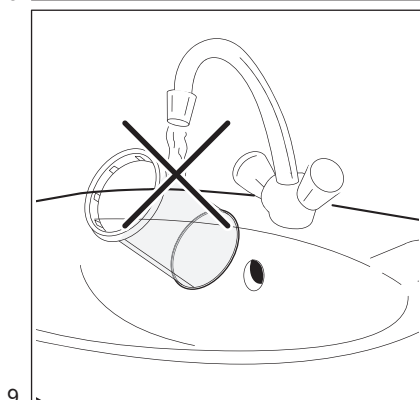

To preserve the positive impact of the filter on the environment, avoid the use of water to clean the filter cartridge. Instead, throw away the waste collected by the filter cartridge in the general dry waste (avoid dispersion of plastic fibre in water ambient).

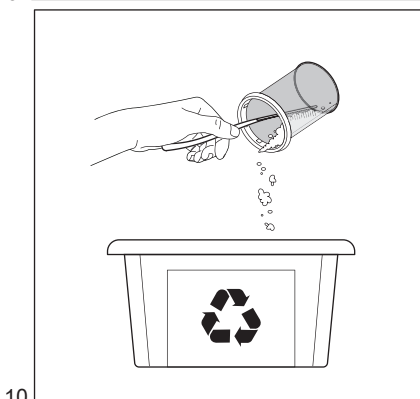

After the water has been emptied from the cartridge, remove any dirt and microfibres from inside the cartridge and dispose of it in DRY general waste. A paper towel can be used to collect as much material as possible.

**CAUTION!**

**Waste collected by the cartridge contains microfibres, detergent residuals and dirt. IT MUST be disposed of in general dry waste.**



After the cartridge cleaning operation, the brush spatula could be dirty and full of plastic fibres. To preserve the positive impact on the environment, clean it with common paper towels and dispose of it to general dry waste

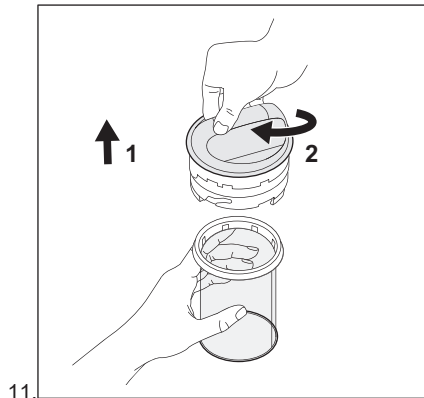

11.



To replace the cartridge, refer to Picture 11:

1. Insert the cartridge.
2. Hold the cartridge in your hand, then with the other hand turn the cover clockwise from unlock symbol to lock symbol.

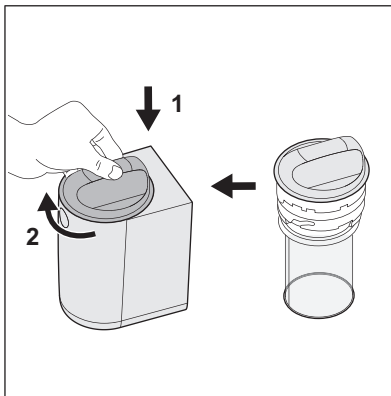

12.



To close the filter, refer to the movements in Picture 12:

1. Insert the cover (+ cartridge) inside the body from the top.
2. Rotate the cover clockwise from unlock symbol to lock symbol.

For any additional information maintenance and cleaning, please watch the video. A dedicated QR code is available at the beginning of this user manual.



### **CAUTION!**

**Ensure to have closed lid before proceeding with the next washing cycle.**



## **WARNINGS**

In case of a washing break period longer than a full week (e.g. holiday, trip), it is suggested to empty the cartridge and clean the filter to avoid creation of unexpected smell into the environment of the filter.

It is necessary to clean the cartridge in wet condition in order not to damage it, avoiding the malfunctioning at next cycles used.

The filtration system is provided with spare a cartridge in order to restart immediately with your laundry routine in case of cartridge damage

### **Cartridge replacement and disposal**

**Cartridge has limited life, approximately six months, since cleaning operation can damage the net, compromising filter performance. 1 spare cartridge part is included in the box.**



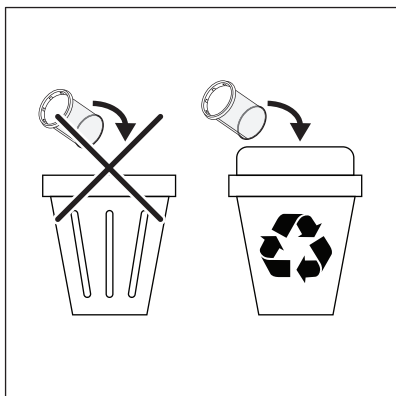

**i** Put the waste from the filter into a suitable recycling container.

When cartridge has to be replaced, please follow these 2 simple steps:

1. Clean the damaged cartridge carefully.
2. Put the cartridge and the waste in to a recycle bin.

**i** For additional cartridge spare parts use only original parts. Cartridges are sold in any Electrolux/AEG service centre or even online.

## Appendixes

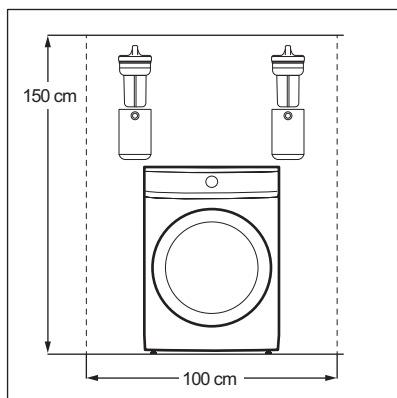

**Appendix for Front Loader washing machine.**

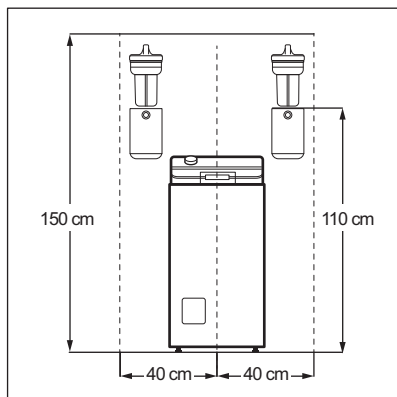

**Appendix for Top Loader washing machine.**







**Electrolux**



157044720-B-392022