

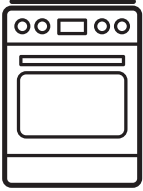

**Electrolux**



**LKI66441NK**

**EN** User Manual | **Cooker**

## WE'RE THINKING OF YOU

Thank you for purchasing an Electrolux appliance. You've chosen a product that brings with it decades of professional experience and innovation. Ingenious and stylish, it has been designed with you in mind. So whenever you use it, you can be safe in the knowledge that you'll get great results every time.

Welcome to Electrolux.

Visit our website to:



Get usage advice, brochures, trouble shooter, service and repair information:  
[www.electrolux.com/support](http://www.electrolux.com/support)



Register your product for better service:  
[www.registerelectrolux.com](http://www.registerelectrolux.com)



Buy Accessories, Consumables and Original spare parts for your appliance:  
[www.electrolux.com/shop](http://www.electrolux.com/shop)

## CUSTOMER CARE AND SERVICE

Always use original spare parts.

When contacting our Authorised Service Centre, ensure that you have the following data available: Model, PNC, Serial Number.

The information can be found on the rating plate.

 Warning / Caution-Safety information

 General information and tips

 Environmental information

Subject to change without notice.

## CONTENTS

|                                   |    |
|-----------------------------------|----|
| 1. SAFETY INFORMATION.....        | 3  |
| 2. SAFETY INSTRUCTIONS.....       | 5  |
| 3. INSTALLATION.....              | 8  |
| 4. PRODUCT DESCRIPTION.....       | 9  |
| 5. BEFORE FIRST USE.....          | 10 |
| 6. HOB - DAILY USE.....           | 11 |
| 7. HOB - HINTS AND TIPS.....      | 17 |
| 8. HOB - CARE AND CLEANING.....   | 18 |
| 9. OVEN - DAILY USE.....          | 19 |
| 10. OVEN - CLOCK FUNCTIONS.....   | 22 |
| 11. OVEN - HINTS AND TIPS.....    | 23 |
| 12. OVEN - CARE AND CLEANING..... | 35 |
| 13. TROUBLESHOOTING.....          | 38 |
| 14. ENERGY EFFICIENCY.....        | 40 |
| 15. ENVIRONMENTAL CONCERNS.....   | 42 |

## 1. ⚠ SAFETY INFORMATION

Before the installation and use of the appliance, carefully read the supplied instructions. The manufacturer is not responsible for any injuries or damage that are the result of incorrect installation or usage. Always keep the instructions in a safe and accessible location for future reference.

### 1.1 Children and vulnerable people safety

- This appliance can be used by children aged from 8 years and above and persons with reduced physical, sensory or mental capabilities or lack of experience and knowledge if they have been given supervision or instruction concerning the use of the appliance in a safe way and understand the hazards involved. Children of less than 8 years of age and persons with very extensive and complex disabilities shall be kept away from the appliance unless continuously supervised.
- Children should be supervised to ensure that they do not play with the appliance.
- Keep all packaging away from children and dispose of it appropriately.
- **WARNING:** The appliance and its accessible parts become hot during use. Keep children and pets away from the appliance when in use and when cooling down.
- If the appliance has a child safety device, it should be activated.
- Children shall not carry out cleaning and user maintenance of the appliance without supervision.

### 1.2 General Safety

- This appliance is for cooking purposes only.
- This appliance is designed for single household domestic use in an indoor environment.
- This appliance may be used in, offices, hotel guest rooms, bed & breakfast guest rooms, farm guest houses and other

similar accommodation where such use does not exceed (average) domestic usage levels.

- Only a qualified person must install this appliance and replace the cable.
- This appliance is intended for use up to an altitude of 2000 m above sea level.
- This appliance is not intended to be used on ships, boats or vessels.
- Do not install the appliance behind a decorative door in order to avoid overheating.
- Do not install the appliance on a platform.
- Do not operate the appliance by means of an external timer or separate remote-control system.
- **WARNING:** Unattended cooking on a hob with fat or oil can be dangerous and may result in fire.
- Never use water to extinguish the cooking fire. Switch off the appliance and cover flames with e.g. a fire blanket or lid.
- **CAUTION:** The cooking process has to be supervised. A short term cooking process has to be supervised continuously.
- **WARNING:** Danger of fire: Do not store items on the cooking surfaces.
- Do not use a steam cleaner to clean the appliance.
- Do not use harsh abrasive cleaners or sharp metal scrapers to clean the glass door or the glass of hinged lids of the hob since they can scratch the surface, which may result in shattering of the glass.
- Metallic objects such as knives, forks, spoons and lids should not be placed on the hob surface since they can get hot.
- If the glass ceramic surface / glass surface is cracked, switch off the appliance and unplug it from the mains. In case the appliance is connected to the mains directly using junction box, remove the fuse to disconnect the appliance from power supply. In either case contact the Authorised Service Centre.

- After use, switch off the hob element by its control and do not rely on the pan detector.
- **WARNING:** The appliance and its accessible parts become hot during use. Care should be taken to avoid touching heating elements.
- Always use oven gloves to remove or insert accessories or ovenware.
- Before maintenance, cut the power supply.
- **WARNING:** Ensure that the appliance is switched off before replacing the lamp to avoid the possibility of electric shock.
- If the mains power supply cable is damaged, it must be replaced by the manufacturer, its Authorised Service Centre or similarly qualified persons to avoid an electrical hazard.
- Use only the food sensor (core temperature sensor) recommended for this appliance.
- Be careful when you touch the storage drawer. It can get hot.
- To remove the shelf supports first pull the front of the shelf support and then the rear end away from the side walls. Install the shelf supports in the opposite sequence.
- **WARNING:** Use only hob guards designed by the manufacturer of the cooking appliance or indicated by the manufacturer of the appliance in the instructions for use as suitable or hob guards incorporated in the appliance. The use of inappropriate guards can cause accidents.

## 2. SAFETY INSTRUCTIONS

### 2.1 Installation

 **WARNING!**

Only a qualified person must install this appliance.

- Remove all the packaging.
- Do not install or use a damaged appliance.
- Follow the installation instructions supplied with the appliance.
- Always take care when moving the appliance as it is heavy. Always use safety gloves and enclosed footwear.
- Do not pull the appliance by the handle.
- The kitchen cabinet and the recess must have suitable dimensions.
- Keep the minimum distance from other appliances and units.
- Install the appliance in a safe and suitable place that meets installation requirements.
- Parts of the appliance carry current. Close the appliance with furniture to prevent touching the dangerous parts.

- The sides of the appliance must stay next to appliances or units with the same height.
- Do not install the appliance adjacent to a door or under a window. This prevents hot cookware to fall from the appliance when the door or the window is opened.
- Make sure to install a stabilizing means in order to prevent tipping of the appliance. Refer to Installation chapter.

## 2.2 Electrical Connection

### **WARNING!**

Risk of fire and electric shock.

- All electrical connections should be made by a qualified electrician.
- The appliance must be earthed.
- Make sure that the parameters on the rating plate are compatible with the electrical ratings of the mains power supply.
- Always use a correctly installed shockproof socket.
- Do not use multi-plug adapters and extension cables.
- Do not let mains cables touch or come near the appliance door or the niche below the appliance, especially when it operates or the door is hot.
- The shock protection of live and insulated parts must be fastened in such a way that it cannot be removed without tools.
- Connect the mains plug to the mains socket only at the end of the installation. Make sure that there is access to the mains plug after the installation.
- If the mains socket is loose, do not connect the mains plug.
- Do not pull the mains cable to disconnect the appliance. Always pull the mains plug.
- Use only correct isolation devices: line protecting cut-outs, fuses (screw type fuses removed from the holder), earth leakage trips and contactors.
- The electrical installation must have an isolation device which lets you disconnect the appliance from the mains at all poles. The isolation device must have a contact opening width of minimum 3 mm.

- Fully close the appliance door before you connect the mains plug to the mains socket.

## 2.3 Use

### **WARNING!**

Risk of injury and burns.  
Risk of electrical shock.

- Do not change the specification of this appliance.
- Make sure that the ventilation openings are not blocked.
- Do not let the appliance stay unattended during operation.
- Deactivate the appliance after each use.
- Be careful when you open the appliance door while the appliance is in operation. Hot air can release.
- Do not operate the appliance with wet hands or when it has contact with water.
- Do not use the appliance as a work surface or as a storage surface.
- Users with a pacemaker must keep a distance of minimum 30 cm from the induction cooking zones when the appliance is in operation.

### **WARNING!**

Risk of fire and explosion

- Fats and oil when heated can release flammable vapours. Keep flames or heated objects away from fats and oils when you cook with them.
- The vapours that very hot oil releases can cause spontaneous combustion.
- Used oil, that can contain food remnants, can cause fire at a lower temperature than oil used for the first time.
- Do not put flammable products or items that are wet with flammable products in, near or on the appliance.
- Do not let sparks or open flames to come in contact with the appliance when you open the door.
- Open the appliance door carefully. The use of ingredients with alcohol can cause a mixture of alcohol and air.

 **WARNING!**

Risk of damage to the appliance.

- To prevent damage or discoloration to the enamel:
  - do not put ovenware or other objects in the appliance directly on the bottom.
  - do not put aluminium foil on the appliance or directly on the bottom of cavity.
  - do not put water directly into the hot appliance.
  - do not keep moist dishes and food in the appliance after you finish the cooking.
  - be careful when you remove or install the accessories.
- Discoloration of the enamel or stainless steel has no effect on the performance of the appliance.
- Use a deep pan for moist cakes. Fruit juices cause stains that can be permanent.
- Do not keep hot cookware on the control panel.
- Do not let cookware boil dry.
- Be careful not to let objects or cookware fall on the appliance. The surface can be damaged.
- Do not activate the cooking zones with empty cookware or without cookware.
- Cookware made of cast iron, aluminium or with a damaged bottom can cause scratches. Always lift these objects up when you have to move them on the cooking surface.

## 2.4 Care and Cleaning

 **WARNING!**

Risk of injury, fire, or damage to the appliance.

- Before maintenance, deactivate the appliance.  
Disconnect the mains plug from the mains socket.
- Make sure the appliance is cold. There is the risk that the glass panels can break.
- Replace immediately the door glass panels when they are damaged. Contact the Authorised Service Centre.

- Be careful when you remove the door from the appliance. The door is heavy!
- Fat and food remaining in the appliance can cause fire.
- Clean regularly the appliance to prevent the deterioration of the surface material.
- Make sure the cavity and the door are wiped dry after each use. Steam produced during the operation of the appliance condensates on cavity walls and can cause corrosion. To decrease the condensation operate the appliance for 10 minutes before cooking.
- Clean the appliance with a moist soft cloth. Use only neutral detergents. Do not use abrasive products, abrasive cleaning pads, solvents or metal objects.
- If you use an oven spray, follow the safety instructions on the packaging.
- Do not clean the catalytic enamel (if applicable) with any kind of detergent.

## 2.5 Internal lighting

 **WARNING!**

Risk of electric shock.

- Concerning the lamp(s) inside this product and spare part lamps sold separately: These lamps are intended to withstand extreme physical conditions in household appliances, such as temperature, vibration, humidity, or are intended to signal information about the operational status of the appliance. They are not intended to be used in other applications and are not suitable for household room illumination.
- This product contains a light source of energy efficiency class G.
- Use only lamps with the same specifications.

## 2.6 Service

- To repair the appliance contact the Authorised Service Centre.
- Use original spare parts only.

## 2.7 Disposal

### **WARNING!**

Risk of injury or suffocation.

- Contact your municipal authority for information on how to dispose of the appliance.

- Disconnect the appliance from the mains supply.
- Cut off the mains electrical cable close to the appliance and dispose of it.
- Remove the door catch to prevent children or pets from becoming trapped in the appliance.

## 3. INSTALLATION

### **WARNING!**

Refer to Safety chapters.

### 3.1 Technical data

#### Dimensions

|        |              |
|--------|--------------|
| Height | 850 - 936 mm |
| Width  | 596 mm       |
| Depth  | 600 mm       |

### 3.2 Electrical installation

#### **WARNING!**

The manufacturer is not responsible if you do not follow the safety precautions from Safety chapters.

This appliance is supplied with a main cable and without a main plug.

#### **WARNING!**

The power cable must not touch the part of the appliance shaded in the illustration.

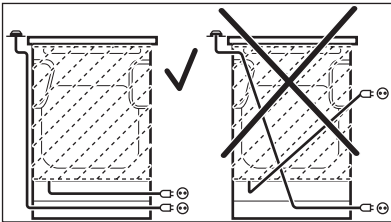

### 3.3 Anti-tilt protection

#### **CAUTION!**

Install the anti-tilt protection to prevent the appliance from falling under incorrect loads. The anti-tilt protection only works when the appliance is put in a correct area.

Your appliance has the symbols shown on the pictures (if applicable) to remind you about the installation of the anti-tilt protection.

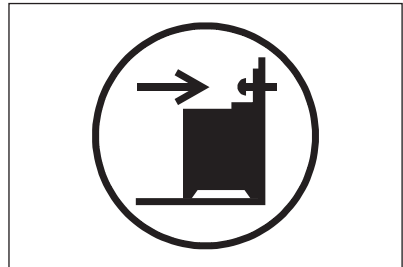

#### **i**

Make sure you install the anti-tilt protection at the correct height.



For more information about the installation of the appliance refer to a separate installation booklet

## 4. PRODUCT DESCRIPTION

### 4.1 General overview

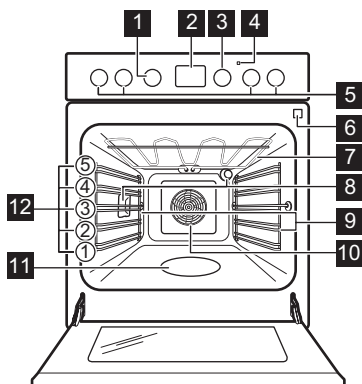

- 1 Knob for the oven functions
- 2 Display
- 3 Knob for the temperature
- 4 Temperature indicator / symbol
- 5 Knobs for the hob
- 6 Socket for the core temperature sensor
- 7 Heating element
- 8 Lamp
- 9 Shelf support, removable
- 10 Fan
- 11 Cavity embossment
- 12 Shelf positions

### 4.2 Hob overview

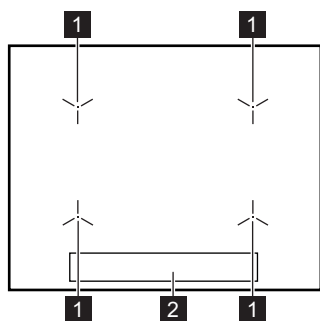

- 1 Induction cooking zone
- 2 Control Panel

### 4.3 Accessories

- **Wire shelf**  
For cookware, cake tins, roasts.
- **Baking tray**  
For cakes and biscuits.
- **Grill- / Roasting pan**  
To bake and roast or as pan to collect fat.
- **AirFry tray**

- To fry food with less oil or without baking paper.
- **Core temperature sensor**  
To measure how far the food is cooked.
- **Storage drawer**  
The storage drawer is below the oven cavity.

## 5. BEFORE FIRST USE

### **WARNING!**

Refer to Safety chapters.

### 5.1 Initial Cleaning

Remove all accessories and removable shelf supports from the oven.



Refer to "Care and cleaning" chapter.

Clean the oven and the accessories before the first use.

Put the accessories and the removable shelf supports back to their initial position.



### 5.2 Using the sensor fields

To activate the function press and hold the selected symbol on the display for at least 1 second.

### 5.3 Setting the time

You must set the time before you operate the oven.

The  flashes when you connect the appliance to the electrical supply, when there was a power cut or when the timer is not set.

Press the  or  to set the correct time. After approximately five seconds, the flashing stops and the display shows the time of day you set.

### 5.4 Changing the time



You cannot change the time of day if any of the functions operates.



Press  again and again until the indicator for the Time of Day function flashes. To set a new time, refer to "Setting the time".

### 5.5 Retractable knobs

To use the appliance press the knob. The knob comes out.

### 5.6 Preheating

Preheat the empty oven before first use.

1. Set the function . Set the maximum temperature.
2. Let the oven operate for 1 hour.
3. Set the function . Set the maximum temperature.
4. Let the oven operate for 15 minutes.
5. Set the function . Set the maximum temperature.
6. Let the oven operate for 15 minutes.
7. Turn off the oven and let it cool down. Accessories can become hotter than usual. The oven can emit an odour and smoke. Make sure that the airflow in the room is sufficient.

### 5.7 Opening and closing the door with the mechanical door lock

The mechanical door lock is activated by default.

To open the door move the lock to the right.

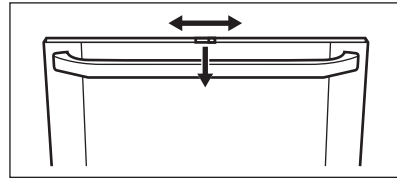

Close the door without pressing the lever.

### 5.8 Deactivating the mechanical door lock - in the main oven

1. Press the door trim B at each side. The seal releases.

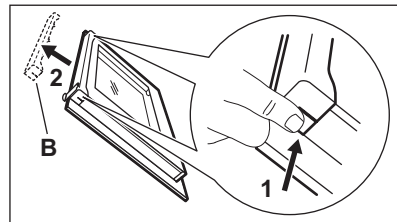

2. Pull the door trim up and remove it.

3. Remove the lever 1, move it to the right 2 and put it back in.

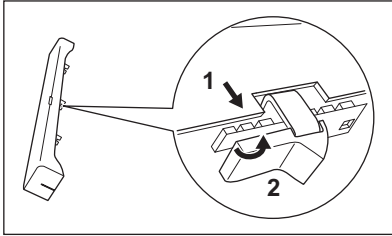

4. Hold the door trim B at each side and position it on the inner edge of the door. Put the door trim into the top edge of the door.

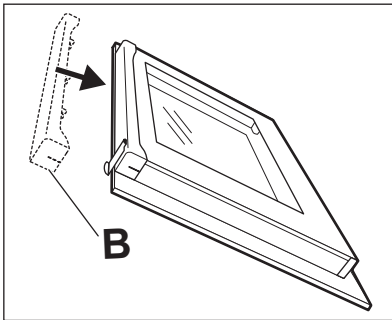

### Activating the mechanical door lock

Do the above procedure again and move the lever back to the left.



Deactivating the appliance does not deactivate the mechanical door lock.

## 6. HOB - DAILY USE



### WARNING!

Refer to Safety chapters.

### 6.1 Hob control panel

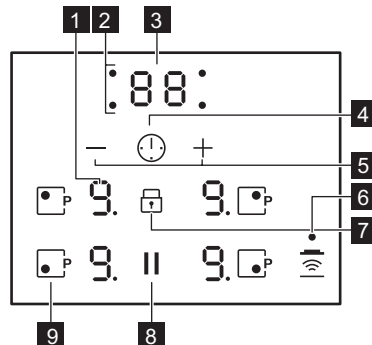

Use the sensor fields to operate the appliance. The displays, indicators and sounds tell which functions operate.



| Sensor field | Function | Comment                           |   |
|--------------|----------|-----------------------------------|---|
| 1            | -        | Heat setting display              | To show the heat setting.                                   |
| 2            | -        | Timer indicators of cooking zones | To show for which zone you set the time.                    |
| 3            | -        | Timer display                     | To show the time in minutes.                                |
| 4            |          | -                                 | To select the cooking zone.                                 |
| 5            | + / -    | -                                 | To increase or decrease the time.                           |
| 6            |          | Hob²Hood                          | To activate and deactivate the manual mode of the function. |
| 7            |          | Lock / Child Safety Device        | To lock / unlock the control panel.                         |
| 8            |          | Pause                             | To activate and deactivate the function.                    |
| 9            |          | PowerBoost                        | To activate and deactivate the function.                    |

## 6.2 Heat setting displays

| Display | Description  |
|---------|--|
|         | The cooking zone is deactivated.   |
|         | The cooking zone operates.<br>The dot means a change by half of a heating level.                 |
|         | Pause operates.  |
|         | Automatic Heat Up operates.  |
|         | PowerBoost operates.   |
|         | There is a malfunction.  |
|         | OptiHeat Control (3 step Residual heat indicator): continue cooking / keep warm / residual heat. |
|         | Lock / Child Safety Device operates.   |
|         | Incorrect or too small cookware or no cookware on the cooking zone.                              |
|         | Automatic Switch Off operates.   |

### 6.3 OptiHeat Control (3 step Residual heat indicator)

#### **WARNING!**

 /  /  As long as the indicator is on, there is a risk of burns from residual heat.

The induction cooking zones produce the heat necessary for the cooking process directly in the bottom of the cookware. The glass ceramic is heated by the heat of the cookware.

The indicators appear when a cooking zone is hot. They show the level of the residual heat for the cooking zones you are currently using:

 - continue cooking,

 - keep warm,

 - residual heat.

The indicator may also appear:

- for the neighbouring cooking zones even if you are not using them,
- when hot cookware is placed on cold cooking zone,
- when the hob is deactivated but the cooking zone is still hot.

The indicator disappears when the cooking zone has cooled down.



### 6.4 The heat setting

Turn the knob for the heating functions to select a heating function. To deactivate it turn the knob to the off position **0**.

### 6.5 Automatic Switch Off

**The function deactivates the hob automatically if:**

- all cooking zones are deactivated,
- you do not set the heat setting after you activate the hob,
- you spill something or put something on the control panel for more than 10 seconds (a pan, a cloth, etc.). An acoustic signal sounds and the hob deactivates. Remove the object or clean the control panel.

- the hob gets too hot (e.g. when a saucepan boils dry). Let the cooking zone cool down before you use the hob again.
- you use incorrect cookware. The symbol  comes on and the cooking zone deactivates automatically after 2 minutes.
- you do not deactivate a cooking zone or change the heat setting. After some time  comes on and the hob deactivates.

**The relation between the heat setting and the time after which the hob deactivates:**

| Heat setting  | The hob deactivates after |
|---|---------------------------|
|  1 - 2 | 6 hours                   |
| 3 - 4   | 5 hours                   |
| 5   | 4 hours                   |
| 6 - 9   | 1.5 hour                  |

### 6.6 Automatic Heat Up

If you activate this function you can get a necessary heat setting faster. The function sets the highest heat setting for some time and then decreases to the correct heat setting.



To activate the function a cooking zone must be cold.

**To activate the function for a cooking zone:** turn the knob for a cooking zone to the **A** position.  shows on the display. Immediately set the correct heat setting.

**To deactivate the function:** turn the knob to the off position.

### 6.7 PowerBoost

This function makes more power available to the induction cooking zones. The function can be activated for the induction cooking zone only for a limited period of time. After this time the induction cooking zone automatically sets back to the highest heat setting.

**To activate the function for a cooking zone:** touch .  comes on.

**To deactivate the function:** change the heat setting.

## 6.8 Timer

### Count Down Timer



You can use this function to set how long the cooking zone should operate for a single cooking session.



First set the heat setting for the cooking zone then set the function.

**To set the cooking zone:** touch  again and again until the indicator of a necessary cooking zone comes on.

**To activate the function:** touch  of the timer to set the time (00 - 99 minutes). When the indicator of the cooking zone starts to flash slowly the time counts down.

**To see the remaining time:** set the cooking zone with . The indicator of the cooking zone starts to flash quickly. The display shows the remaining time.

**To change the time:** set the cooking zone with . Touch  or .

**To deactivate the function:** set the cooking zone with  and touch . The remaining time counts back to 00. The indicator of the cooking zone goes out.







When the time comes to an end, the sound operates and 00 flashes. The cooking zone deactivates.

**To stop the sound:** touch .

### CountUp Timer



You can use this function to monitor how long the cooking zone operates.

**To set the cooking zone:** touch  again and again until the indicator of a necessary cooking zone comes on.

**To activate the function:** touch  of the timer.  comes on. When the indicator of the cooking zone starts to flash slowly the time counts up. The display switches between  and counted time (minutes).



## To see how long the cooking zone

**operates:** set the cooking zone with . The indicator of the cooking zone starts to flash quickly. The display shows how long the zone operates.

**To deactivate the function:** set the cooking zone with  and touch  or . The indicator of the cooking zone goes out.

### Minute Minder

You can use this function as a **Minute Minder** when the hob is activated and the cooking zones do not operate. The heat setting display shows .

**To activate the function:** touch . Touch  or  of the timer to set the time. Cooking zones display deactivates automatically after 10 seconds. When the time comes to an end, the sound operates and 00 flashes.

**To stop the sound:** touch .

**To deactivate the function:** activate for a short time and deactivate left front cooking zone.





The function has no effect on the operation of the cooking zones.

## 6.9 Pause

This function sets all cooking zones that operate to the lowest heat setting.

The function does not stop the timer functions.

**1. To activate the function:** press .  comes on. The heat setting is lowered to 1.

**2. To deactivate the function:** press . The previous heat setting comes on.





If you change the heat setting, the function stops and the display shows the new heat setting.

## 6.10 Lock

You can lock the sensors on the hob while cooking zones operate.

**Set the heat setting first.**

**To activate the function:** touch .  comes on for 4 seconds. The Timer stays on.





**To deactivate the function:** touch . The previous heat setting comes on.









When you deactivate the hob, you also deactivate this function.

## 6.11 Child Safety Device





This function prevents an accidental operation of the hob.



**To activate the function:** the hob must be deactivated. Touch  for 4 seconds until  flashes. Touch .  comes on for 4 seconds.

**To deactivate the function:** the hob must be deactivated. Touch  for 4 seconds until  flashes. Touch .  comes on for 4 seconds.

**To override the function for only one cooking time:** activate a cooking zone.  comes on. Touch  for 4 seconds until  comes on for all zones. **Set the heat setting in 4 seconds.** You can operate the hob. When you deactivate the appliance the function operates again.

## 6.12 OffSound Control (Deactivation and activation of the sounds)

Deactivate the hob. Touch  for 3 seconds. Touch  for 3 seconds.  or  comes on. Touch  of the timer to choose one of the following:

-  - the sounds are off
-  - the sounds are on.

To confirm your selection wait until the hob deactivates automatically.

When the function is set to  you can hear the sounds only when:

- Minute Minder comes down
- Count Down Timer comes down
- you put something on the control panel.

## 6.13 Hob<sup>2</sup>Hood

It is an advanced automatic function which connects the hob to a special hood. Both the hob and the hood have an infrared signal communicator. Speed of the fan is defined automatically on basis of mode setting and temperature of the hottest cookware on the hob. You can also operate the fan from the hob manually.



For most of the hoods the remote system is originally deactivated. Activate it before you use the function. For more information refer to hood user manual.

### Operating the function automatically

To operate the function automatically set the automatic mode to H1 – H6. The hob is originally set to H5. The hood reacts whenever you operate the hob. The hob recognizes temperature of the cookware automatically and adjusts the speed of the fan.

### Automatic modes

|                       | Automatic light | Boiling <sup>1)</sup> | Frying <sup>2)</sup> |
|-----------------------|-----------------|-----------------------|----------------------|
| Mode H0               | Off             | Off                   | Off                  |
| Mode H1               | On              | Off                   | Off                  |
| Mode H2 <sup>3)</sup> | On              | Fan speed 1           | Fan speed 1          |
| Mode H3               | On              | Off                   | Fan speed 1          |
| Mode H4               | On              | Fan speed 1           | Fan speed 1          |
| Mode H5               | On              | Fan speed 1           | Fan speed 2          |

| Automatic light |    | Boiling <sup>1)</sup> | Frying <sup>2)</sup> |
|-----------------|----|-----------------------|----------------------|
| Mode H6         | On | Fan speed 2           | Fan speed 3          |

- 1) The hob detects the boiling process and activates fan speed in accordance with automatic mode.
- 2) The hob detects the frying process and activates fan speed in accordance with automatic mode.
- 3) This mode activates the fan and the light and does not rely on the temperature.

### Changing the automatic mode

1. Deactivate the appliance.
2. Press until you hear a beep and keep it pressed until you hear the second beep.
3. Press for 3 seconds until or comes on.
4. Press until H and a digit (0 - 6) comes on. H5 is the default setting.
5. Press of the Timer to select the desired mode (H0 - H6). The chosen mode activates automatically after 10 seconds.



To operate the hood directly on the hood panel deactivate the automatic mode of the function.



When you finish cooking and deactivate the hob, the hood fan may still operate for a certain period of time. After that time the system deactivates the fan automatically and prevents you from accidental activation of the fan for the next 30 seconds.

### Operating the fan speed manually

You can also operate the function manually.

To do that touch when the hob is active. This deactivates automatic operation of the function and allows you to change the fan speed manually. When you press you

raise the fan speed by one. When you reach an intensive level and press again you will set fan speed to 0 which deactivates the hood fan. To start the fan again with fan speed 1 touch .



To activate automatic operation of the function, deactivate the hob and activate it again.

### Activating the light

You can set the hob to activate the light automatically whenever you activate the hob. To do so set the automatic mode to H1 – H6.



The light on the hood deactivates 2 minutes after deactivating the hob.

## 6.14 Power management function

- All cooking zones are connected to one phase. See the illustration.
- The phase has a maximum electricity load.
- The function divides the power between cooking zones.
- The function activates when the total electricity load of the cooking zones is exceeded.
- The function reduces the power of the other cooking zones.
- The heat setting display of the reduced zones changes between two levels.

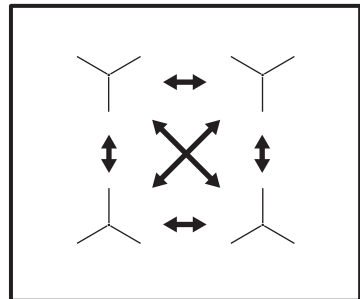



## 7. HOB - HINTS AND TIPS

### **WARNING!**

Refer to Safety chapters.

### 7.1 Cookware



For induction cooking zones a strong electro-magnetic field creates the heat in the cookware very quickly.



Use the induction cooking zones with suitable cookware.

#### Cookware material

- **correct:** cast iron, steel, enamelled steel, stainless steel, multi-layer bottom (with a correct marking from a manufacturer).
- **not correct:** aluminium, copper, brass, glass, ceramic, porcelain.

#### Cookware is suitable for an induction hob if:

- water boils very quickly on a zone set to the highest heat setting.
- a magnet pulls on to the bottom of the cookware.



The bottom of the cookware must be as thick and flat as possible.  
Ensure pan bases are clean and dry before placing on the hob surface.

#### Cookware dimensions

Induction cooking zones adapt to the dimension of the bottom of the cookware automatically.

The cooking zone efficiency is related to the diameter of the cookware. The cookware with a diameter smaller than the minimum receives only a part of the power generated by the cooking zone.

### 7.2 Minimum cookware diameter

| Cooking zone | Cookware diameter (mm) | Power (W) |
|--------------|------------------------|-----------|
| Left rear    | 125 - 140              | 1400/2500 |
| Right rear   | 145 - 180              | 1800/2800 |
| Right front  | 145 - 180              | 1800/2800 |
| Left front   | 180 - 210              | 2300/3600 |

### 7.3 The noises during operation

#### If you can hear:

- crack noise: cookware is made of different materials (a sandwich construction).
- whistle sound: you use a cooking zone with a high power level and the cookware is made of different materials (a sandwich construction).
- humming: you use a high power level.
- clicking: electric switching occurs.
- hissing, buzzing: the fan operates.

**The noises are normal and do not indicate any malfunction.**

### 7.4 Öko Timer (Eco Timer)



To save energy, the heater of the cooking zone deactivates before the count down timer sounds. The difference in the operation time depends on the heat setting level and the length of the cooking operation.

### 7.5 Examples of cooking applications

The correlation between the heat setting of a zone and its consumption of power is not linear. When you increase the heat setting, it is not proportional to the increase of the consumption of power. It means that a cooking zone with the medium heat setting uses less than a half of its power.



The data in the table is for guidance only.

| Heat setting   | Use to:  | Time (min)   | Hints  |
|--|--|--------------|--|
|  - 1 | Keep cooked food warm.   | as necessary | Put a lid on the cookware.   |
| 1 - 2.   | Hollandaise sauce, melt: butter, chocolate, gelatine.  | 5 - 25       | Mix from time to time.   |
| 2.   | Solidify: fluffy omelettes, baked eggs.  | 10 - 40      | Cook with a lid on.  |
| 2 - 3.   | Simmer rice and milkbased dishes, heat up ready-cooked meals.  | 25 - 50      | Add at least twice as much liquid as rice, mix milk dishes halfway through the procedure.                            |
| 3 - 4.   | Stew vegetables, fish, meat.   | 20 - 45      | Add a few tablespoons of water. Check the water amount during the process.   |
| 4 - 5.   | Steam potatoes and other vegetables.   | 20 - 60      | Cover the bottom of the pot with 1-2 cm of water. Check the water level during the process. Keep the lid on the pot. |
| 4 - 5.   | Cook larger quantities of food, stews and soups.   | 60 - 150     | Up to 3 l of liquid plus ingredients.  |
| 5 - 7  | Gentle fry: escalope, veal cordon bleu, cutlets, rissoles, sausages, liver, roux, eggs, pancakes, doughnuts. | as necessary | Turn over when needed.   |
| 7 - 8  | Heavy fry, hash browns, loin steaks, steaks.   | 5 - 15       | Turn over when needed.   |
| 9  | Boil water, cook pasta, sear meat (goulash, pot roast), deep-fry chips.                                      |              |  |
|      | Boil large quantities of water. PowerBoost is activated.   |              |  |

## 8. HOB - CARE AND CLEANING

### WARNING!

Refer to Safety chapters.

### 8.1 General information

- Clean the hob after each use.
- Always use cookware with a clean base.
- Scratches or dark stains on the surface have no effect on how the hob operates.
- Use a special cleaner suitable for the surface of the hob.
- Use a special scraper for the glass.

### 8.2 Cleaning the hob

- **Remove immediately:** melted plastic, plastic foil, salt, sugar and food with sugar,

otherwise, the dirt can cause damage to the hob. Take care to avoid burns. Use a special hob scraper on the glass surface at an acute angle and move the blade on the surface.









- **Remove when the hob is sufficiently cool:** limescale rings, water rings, fat stains, shiny metallic discoloration. Clean the hob with a moist cloth and a non-abrasive detergent. After cleaning, wipe the hob dry with a soft cloth.
- **Remove shiny metallic discoloration:** use a solution of water with vinegar and clean the glass surface with a cloth.

## 9. OVEN - DAILY USE

### **WARNING!**

Refer to Safety chapters.

### 9.1 Oven functions

| Symbol  | Oven function          | Application   |
|---|------------------------|---|
|  | Off position           | The oven is off.  |
|   | Hot Air                | To bake on up to two shelf positions at the same time and to dry food.<br>Set the temperature 20 - 40 °C lower than for Conventional.   |
|   | Pie / Pizza<br>/AirFry | To bake food on one shelf position for a more intensive browning and a crispy bottom.<br>/To fry food with less oil or without baking paper. For dishes like french fries or pizza.   |
|   | Conventional           | To bake and roast food on one shelf position.   |
|   | Steam Bake             | To add humidity during the cooking. To get the right colour and crispy crust during baking. To give more juiciness during reheating.  |
|   | Max Grill              | To grill flat food in large quantities and to toast bread.  |
|   | Turbo Grilling         | To roast larger meat joints or poultry with bones on one shelf position. Also to make gratins and to brown.   |
|  | Moist Fan Baking       | This function was used to comply with the Energy Efficiency Class and Ecodesign Regulations (according to EU 65/2014 and EU 66/2014). Tests according to: IEC/EN 60350-1.<br>The oven door should be closed during cooking so that the function is not interrupted and to ensure that the oven operates with the highest energy efficiency possible.<br>When you use this function, the temperature in the cavity may differ from the set temperature. The heating power may be reduced. For general energy saving recommendations refer to "Energy Efficiency" chapter, Energy Saving.<br>This function is designed to save energy during cooking. For the cooking instructions refer to "Hints and tips" chapter, Moist Fan Baking.<br>When you use this function the lamp automatically turns off. |



You can defrost food by choosing Moist Fan Baking function without setting the temperature.

## 9.2 Activating and deactivating the oven



**It depends on the model if your appliance has knob symbols, indicators or lamps:**

- The indicator comes on when the oven heats up.
- The lamp comes on when the oven operates.
- The symbol shows whether the knob controls one of the cooking zones, the oven functions or the temperature.

1. Turn the knob for the oven functions to select an oven function.
2. Turn the knob for the temperature to select a temperature.
3. To deactivate the oven turn the knobs for the oven functions and temperature to the off position.

## 9.3 Activating the function: Steam Bake

This function increases humidity while cooking.



**Risk of burns and damage to the appliance.**

Released humidity can cause burns:

- Do not open the appliance door when using the function: Steam Bake.
- Open the appliance door carefully after using the function: Steam Bake.



Refer to "Hints and tips" chapter.

1. Open the oven door.
2. Fill the cavity embossment with tap water. The maximum capacity of the cavity embossment is 250 ml. Fill the cavity embossment with water only when the oven is cold.
3. Turn the function knob: Steam Bake .
4. Turn the temperature knob to set a temperature.
5. Put food in the appliance and close the oven door.

### **CAUTION!**

Do not refill the cavity embossment with water during cooking or when the oven is hot.

6. To turn off the appliance, turn the knobs for the oven functions and temperature to the off position.
7. Remove water from the cavity embossment.

### **WARNING!**

Make sure that the appliance is cold before you remove the remaining water from the cavity embossment.

## 9.4 Cooling fan

When the oven operates, the cooling fan turns on automatically to keep the surfaces of the oven cool. If you turn off the oven, the cooling fan continues to operate until the oven cools down.

## 9.5 Using the core temperature sensor

The core temperature sensor measures the core temperature of the meat.

There are two temperatures to be set:

- The oven temperature. Refer to the table for roasting.
- The core temperature. Refer to the table for the core temperature sensor.

### **CAUTION!**

Only use the core temperature sensor supplied with the appliance, or genuine replacement parts.

1. Put the point of the core temperature sensor into the centre of the meat.
2. Put the plug of the core temperature sensor into the socket on the front of the appliance. The indicator for the core temperature sensor  flashes.

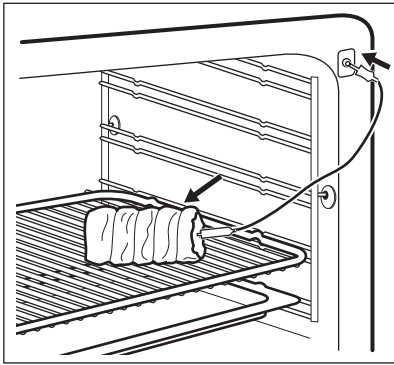

3. Press the button  $\oplus$  or  $\ominus$  to set the core temperature.  
You can set the temperature from 30 °C to 99 °C. Refer to values in the table.
4. Set the oven function and the oven temperature.
5. Press a button to stop the signal.  
An acoustic signal sounds for two minutes, when the meat is at the set core temperature.
6. Deactivate the appliance.
7. Remove the plug of the core temperature sensor from the socket. Remove the meat from the appliance.

If the meat is not cooked to your satisfaction, do the above steps again and set a higher core temperature.

You can change the temperature at any time during the cooking. Press  $\text{⌂}$  to change the set core temperature.

**⚠ WARNING!**

Be careful when you remove the tip and plug of the core temperature sensor. The core temperature sensor is hot. There is a risk of burns.

## 9.6 Inserting the oven accessories

### Deep pan:

Push the deep pan between the guide bars of the shelf support.

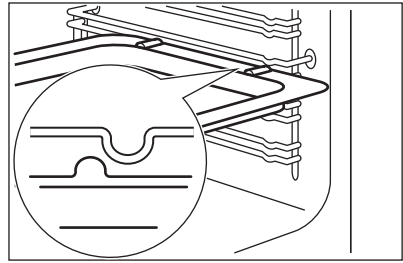

### Wire shelf:

Push the shelf between the guide bars of the shelf support.

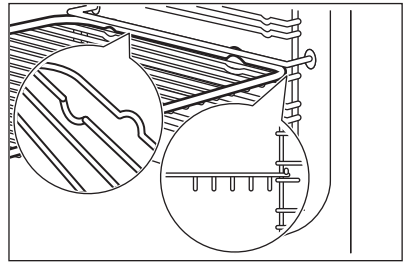

### AirFry tray:

Place the AirFry tray on the third shelf position. Place the baking tray on the first shelf position.

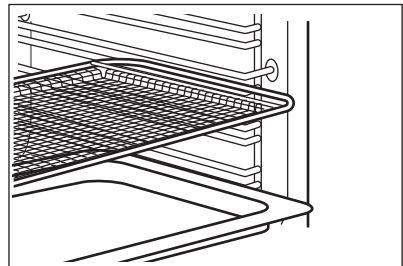

**i**

- All accessories have small indentations at the top of the right and left side to increase safety. The indentations are also anti-tip devices.
- The high rim around the shelf is a device which prevents cookware from slipping.

## 10. OVEN - CLOCK FUNCTIONS

### 10.1 Display

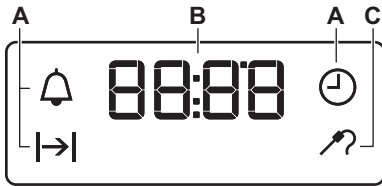

- A. Clock functions
- B. Timer
- C. Food sensor indicator

### 10.2 Buttons

| Button | Function | Description              |
|--------|----------|--------------------------|
| —      | MINUS    | To set the time.         |
|        | CLOCK    | To set a clock function. |
| +      | PLUS     | To set the time.         |

### 10.3 Clock functions

| Clock function |               | Application   |
|----------------|---------------|---|
|                | TIME OF DAY   | To set, change or check the time of day.  |
|                | DURATION      | To set how long the oven works.   |
|                | MINUTE MINDER | To set a countdown. This function has no effect on the operation of the oven. You can set this function at any time, also when the oven is off. |

### 10.4 Setting the DURATION

- Set an oven function and temperature.
- Press again and again until starts to flash.
- Press **+** or **—** to set the DURATION time.

The display shows .

- When the time ends, flashes and an acoustic signal sounds. The appliance deactivates automatically.
- Press any button to stop the acoustic signal.

- Turn the knob for the oven functions and the knob for the temperature to the off position.

### 10.5 Setting the MINUTE MINDER

- Press again and again until starts to flash.
- Press **+** or **—** to set the necessary time. The Minute Minder starts automatically after 5 seconds.
- When the set time ends, an acoustic signal sounds. Press any button to stop the acoustic signal.

- Turn the knob for the oven functions and the knob for the temperature to the off position.

## 10.6 Cancelling the clock functions

- Press the  again and again until the necessary function indicator starts to flash.

- Press and hold .

The clock function goes out after some seconds.

## 11. OVEN - HINTS AND TIPS

### **WARNING!**

Refer to Safety chapters.



The temperature and baking times in the tables are guidelines only. They depend on the recipes and the quality and quantity of the ingredients used.

### 11.1 Baking

For the first baking, use the lower temperature.

### 11.2 Tips on baking

You can extend the baking time by 10 – 15 minutes if you bake cakes on more than one shelf position.

Cakes and pastries at different heights do not always brown equally. There is no need to change the temperature setting if an unequal browning occurs. The differences equalize during baking.

Trays in the oven can distort during baking. When the trays are cold again, the distortions disappear.

| Baking results  | Possible cause   | Remedy   |
|---|--|--|
| The bottom of the cake is not baked sufficiently.               | The shelf position is incorrect.                                   | Put the cake on a lower shelf.                                 |
| The cake sinks and becomes soggy or streaky.                    | The oven temperature is too high.                                  | Next time set slightly lower oven temperature.                 |
|   | The oven temperature is too high and the baking time is too short. | Next time set a longer baking time and lower oven temperature. |
| The cake is too dry.  | The oven temperature is too low.                                   | Next time set higher oven temperature.                         |
|   | The baking time is too long.                                       | Next time set shorter baking time.                             |
| The cake bakes unevenly.  | The oven temperature is too high and the baking time is too short. | Next time set a longer baking time and lower oven temperature. |
|   | The cake batter is not evenly distributed.                         | Next time spread the cake batter evenly on the baking tray.    |
| The cake is not ready in the baking time specified in a recipe. | The oven temperature is too low.                                   | Next time set a slightly higher oven temperature.              |

## 11.3 Hot Air Baking

| Food                            | Temperature (°C) | Time (min)                | Shelf position |
|---------------------------------|------------------|---------------------------|----------------|
| Bread rolls                     | 175 - 185        | 15 - 20                   | 2 + 4          |
| Wholemeal rolls                 | 165 - 180        | 20 - 30                   | 2 + 4          |
| Filled sandwiches               | 170 - 180        | 15 - 20                   | 2 + 4          |
| Pan loaf                        | 170 - 190        | 30 - 40                   | 1 + 4          |
| Pretzels                        | 160 - 170        | 15 - 20                   | 2 + 4          |
| White loaf / Round loaf         | 170 - 180        | 35 - 45                   | 2 + 4          |
| Wholemeal loaf                  | 160 - 170        | 35 - 45                   | 2 + 4          |
| Rye bread, mix                  | 250              | -                         | 2 + 4          |
| - baking                        | 160 - 170        | 60 - 70                   | 2 + 4          |
| Baguettes                       | 180 - 200        | 20 - 30                   | 2 + 4          |
| Pancakes                        | 150 - 160        | 50 - 60                   | 3              |
| Fruit cakes                     | 140 - 150        | 70 - 80                   | 3              |
| Muffins                         | 160 - 170        | 15 - 25                   | 2 + 4          |
| Jam roll                        | 190 - 210        | 6 - 15                    | 3              |
| Buns                            | 185 - 195        | 8 - 15                    | 2 + 4          |
| Long loaf                       | 170 - 180        | 25 - 35                   | 2 + 4          |
| Gingerbread                     | 160 - 170        | 8 - 15                    | 2 + 4          |
| Dish cake                       | 150 - 160        | 30 - 40                   | 2 + 4          |
| Sponge cakes / Madeira cakes    | 150 - 160        | 50 - 60                   | 2              |
| Meringues                       | 90 - 110         | 90 - 120                  | 2 + 4          |
| Meringue bases                  | 90 - 110         | 90 - 120                  | 2 + 4          |
| Biscuits                        | 150 - 160        | 10 - 20                   | 2 + 4          |
| Choux pastry                    | 155 - 165        | 30 - 40                   | 2 + 4          |
| Fruit tarts, short crust pastry | 150 - 160        | pre-baking, bases 10 - 15 | 2 + 4          |
| Fruit tarts, short crust pastry | 150 - 160        | finishing 35 - 45         | 2 + 4          |
| Fruit tarts, crumble pastry     | 170 - 180        | 30 - 40                   | 2 + 4          |

## 11.4 Conventional Baking

| Food        | Temperature (°C) | Time (min) | Shelf position |
|-------------|------------------|------------|----------------|
| Bread rolls | 200 - 225        | 8 - 12     | 3 - 4          |



| Food                            | Temperature (°C) | Time (min)               | Shelf position |
|---------------------------------|------------------|--------------------------|----------------|
| Wholemeal rolls                 | 190 - 200        | 20 - 25                  | 3 - 4          |
| Filled sandwiches               | 200 - 225        | 10 - 12                  | 3 - 4          |
| Ciabatta rolls                  | 210 - 230        | 10 - 20                  | 3 - 4          |
| Focaccia                        | 220 - 230        | 15 - 20                  | 3 - 4          |
| Pita bread                      | 250              | 5 - 15                   | 3 - 4          |
| Pretzels                        | 180 - 200        | 12 - 15                  | 3 - 4          |
| White loaf                      | 190 - 210        | 25 - 40                  | 1 - 2          |
| Ciabatta                        | 210 - 220        | 15 - 25                  | 1 - 2          |
| Wholemeal loaf                  | 180 - 200        | 35 - 45                  | 1 - 2          |
| Rye bread baking                | 180 - 200        | 55 - 65                  | 1              |
| - baking                        | 190              | 55 - 65                  | 1              |
| Baguettes                       | 220 - 230        | 15 - 30                  | 3 - 4          |
| Pancake                         | 170 - 180        | 50 - 60                  | 2 - 3          |
| Dish cake                       | 170 - 180        | 35 - 45                  | 3 - 4          |
| Sponge cakes / Madeira cakes    | 170 - 180        | 40 - 50                  | 1 - 2          |
| Sandwich cake, roll             | 200 - 225        | 8 - 12                   | 3 - 4          |
| Meringues                       | 90 - 110         | 90 - 120                 | 3 - 4          |
| Meringue bases                  | 90 - 110         | 90 - 120                 | 3 - 4          |
| Biscuits                        | 160 - 180        | 6 - 15                   | 3 - 4          |
| Choux pastry                    | 170 - 190        | 30 - 45                  | 3 - 4          |
| Swiss rolls                     | 190 - 210        | 10 - 12                  | 3 - 4          |
| Fruit tarts, short crust pastry | 175 - 200        | pre-baking, roll 10 - 15 | 3 - 4          |
| Fruit tarts, short crust pastry | 170 - 180        | finishing 35 - 45        | 3 - 4          |
| Fruit tarts, crumble pastry     | 190 - 200        | 25 - 35                  | 3 - 4          |
| Marzipan ring cake              | 210 - 230        | 10 - 12                  | 2              |

## 11.5 Hot Air Cooking

| Food          | Temperature (°C) | Time (min) | Shelf position |
|---------------|------------------|------------|----------------|
| Fish, boiling | 150 - 160        | _1)        | 2 + 4          |
| Fish, frying  | 165 - 175        | _1)        | 2 + 4          |

| Food                                | Temperature (°C) | Time (min)            | Shelf position |
|-------------------------------------|------------------|-----------------------|----------------|
| Meatloaf                            | 165 - 175        | 60 - 70               | 2 + 4          |
| Danish meatballs                    | 165 - 175        | 35 - 45               | 2 + 4          |
| Liver pâté                          | 165 - 175        | 65 - 75               | 2 + 4          |
| Potato gratin                       | 175              | 55 - 65               | 2 + 4          |
| Lasagne, home made                  | 175              | 60 - 70               | 2 + 4          |
| Lasagne, frozen                     | 175              | 30 - 45 <sup>2)</sup> | 2 + 4          |
| Pasta gratin                        | 165 - 175        | 40 - 50               | 2 + 4          |
| Chips, frozen                       | 180 - 200        | 30 - 45 <sup>2)</sup> | 2 + 4          |
| Tarts, home made - pre-baking, roll | 165 - 175        | 15 - 20               | 2 + 4          |
| Tarts, home made - finishing        | 165 - 175        | 30 - 40               | 2 + 4          |
| Tarts, frozen                       | 175              | 25 - 35 <sup>2)</sup> | 2 + 4          |

1) When frying or boiling fish, the cooking time depends on the thickness of the fish. The fish is finished when the flesh is white. Test by sticking a fork into the fish. If the flesh comes easily away from the bone, the fish is cooked.

2) With cooking on two levels (double portion) the time is around 1/3 longer than that stated on the packaging. If the time given is 30 mins, then the preparation time will be around 30 + 10 = 40 min.

## 11.6 Conventional Cooking

| Food                                | Temperature (°C) | Time (min)            | Shelf position |
|-------------------------------------|------------------|-----------------------|----------------|
| Fish, boiling                       | 160 - 170        | 1 <sup>1)</sup>       | 2 - 3          |
| Fish, frying                        | 180 - 200        | 1 <sup>1)</sup>       | 2 - 3          |
| Meatloaf                            | 175 - 200        | 45 - 60               | 2 - 3          |
| Danish meatballs                    | 175 - 200        | 30 - 45               | 3 - 4          |
| Liver pâté                          | 180 - 200        | 50 - 60               | 2 - 3          |
| Gratin                              | 180 - 200        | 50 - 60               | 2 - 3          |
| Potato gratin                       | 200              | 55 - 65               | 3 - 4          |
| Lasagne, home made                  | 200              | 50 - 60               | 2 - 3          |
| Lasagne, frozen                     | 175 - 200        | 30 - 45 <sup>2)</sup> | 3 - 4          |
| Pasta gratin                        | 180 - 200        | 30 - 40               | 2 - 3          |
| Chips, frozen                       | 225 - 250        | 20 - 30 <sup>2)</sup> | 3 - 4          |
| Tarts, home made - pre-baking, roll | 190 - 210        | 15 - 25               | 3 - 4          |
| Tarts, home made - finishing        | 190 - 210        | 20 - 30               | 3 - 4          |

| Food          | Temperature (°C) | Time (min)            | Shelf position |
|---------------|------------------|-----------------------|----------------|
| Tarts, frozen | 200 - 225        | 20 - 30 <sup>2)</sup> | 3 - 4          |

1) When frying or boiling fish, the cooking time depends on the thickness of the fish. The fish is finished when the flesh is white. Test by sticking a fork into the fish. If the flesh comes easily away from the bone, the fish is cooked.

2) With cooking on two levels (double portion) the time is around 1/3 longer than that stated on the packaging. If the time given is 30 min, then the preparation time will be around  $30 + 10 = 40$  min.

## 11.7 Pizza Table

| Food   | Temperature (°C)        | Time (min) | Shelf position |
|--|-------------------------|------------|----------------|
| Ciabatta rolls                                   | 200 - 220               | 10 - 20    | 2              |
| Foccacia   | 220 - 230               | 10 - 20    | 2              |
| Ciabatta   | 190 - 200               | 15 - 25    | 2              |
| Fruit tarts, short crust pastry                  | 170 - 180               | 35 - 45    | 2              |
| Fruit tarts, crumble pastry                      | 175 - 200               | 25 - 35    | 2              |
| Pizza, home made (thick - with a lot of topping) | 180 - 200               | 25 - 35    | 1              |
| Pizza, home made (thin crust)                    | 200 - 230 <sup>1)</sup> | 15 - 20    | 1              |
| Pizza, frozen                                    | 190 - 200               | 15 - 20    | 3              |
| Tarts, home made pre-baking, roll                | 175 - 200               | 35 - 45    | 3              |
| Tarts, home made finishing                       | 175 - 200               | 35 - 45    | 3              |
| Tarts, frozen                                    | 190 - 210               | 15 - 25    | 3              |

1) Preheat the oven.

## 11.8 Moist Fan Baking

### Bread and pizza

| Food               | Temperature (°C) | Time (min) | Shelf position |
|--------------------|------------------|------------|----------------|
| Buns               | 180              | 25 - 35    | 3              |
| Frozen pizza 350 g | 190              | 25 - 35    | 3              |

### Cakes in baking tray

| Food       | Temperature (°C) | Time (min) | Shelf position |
|------------|------------------|------------|----------------|
| Swiss roll | 180              | 20 - 30    | 3              |
| Brownie    | 180              | 30 - 40    | 3              |

## Cakes in tin

| Food              | Temperature (°C) | Time (min) | Shelf position |
|-------------------|------------------|------------|----------------|
| Soufflè           | 200              | 30 - 40    | 3              |
| Sponge flan base  | 180              | 20 - 30    | 3              |
| Victoria sandwich | 150              | 25 - 35    | 3              |

## Fish

| Food                  | Temperature (°C) | Time (min) | Shelf position |
|-----------------------|------------------|------------|----------------|
| Fish in pouches 300 g | 180              | 25 - 35    | 3              |
| Whole fish 200 g      | 180              | 25 - 35    | 3              |
| Fish fillet 300 g     | 180              | 25 - 35    | 3              |

## Meat

| Food                | Temperature (°C) | Time (min) | Shelf position |
|---------------------|------------------|------------|----------------|
| Meat in pouch 250 g | 200              | 25 - 35    | 3              |
| Meat skewers 500 g  | 200              | 30 - 40    | 3              |

## Small baked items

| Food                        | Temperature (°C) | Time (min) | Shelf position |
|-----------------------------|------------------|------------|----------------|
| Cookies                     | 180              | 25 - 35    | 3              |
| Macaroons                   | 160              | 25 - 35    | 3              |
| Muffins                     | 180              | 25 - 35    | 3              |
| Savoury cracker             | 170              | 20 - 30    | 3              |
| Short crust pastry biscuits | 150              | 25 - 35    | 3              |
| Tartelettes                 | 170              | 15 - 25    | 3              |

## Vegetarian

| Food                            | Temperature (°C) | Time (min) | Shelf position |
|---------------------------------|------------------|------------|----------------|
| Mixed vegetables in pouch 400 g | 180              | 25 - 35    | 3              |
| Omelette                        | 200              | 20 - 30    | 3              |
| Vegetables on tray 700 g        | 180              | 25 - 35    | 3              |

## 11.9 Steam Bake

### Bakery

| Food                       | Temperature (°C) | Water in the cavity embossment (ml) | Preheating time (min) | Time (min) | Shelf position |
|----------------------------|------------------|-------------------------------------|-----------------------|------------|----------------|
| White bread                | 180              | 150                                 | 10                    | 30 - 40    | 2              |
| Bread rolls                | 200              | 150                                 | 5                     | 20 - 25    | 2              |
| Focaccia                   | 190              | 150                                 | 10                    | 20 - 25    | 1              |
| Homemade pizza             | 230              | 150                                 | 10                    | 15 - 20    | 2              |
| Cookies, scones, croissant | 160              | 150                                 | 10                    | 10 - 20    | 2              |
| Plum cake, cinnamon rolls  | 160              | 150                                 | 10                    | 70 - 80    | 2              |

### Frozen foods

| Food      | Temperature (°C) | Water in the cavity embossment (ml) | Preheating time (min) | Time (min) | Shelf position |
|-----------|------------------|-------------------------------------|-----------------------|------------|----------------|
| Pizza     | 200              | 100                                 | 10                    | 15         | 2              |
| Croissant | 170              | 50                                  | 10                    | 25         | 2              |
| Lasagne   | 200              | 200                                 | 10                    | 35 - 45    | 2              |

### Food regeneration

| Food           | Temperature (°C) | Water in the cavity embossment (ml) | Preheating time (min) | Time (min) | Shelf position |
|----------------|------------------|-------------------------------------|-----------------------|------------|----------------|
| White bread    | 110              | 100                                 | -                     | 30 - 40    | 2              |
| Bread rolls    | 110              | 100                                 | -                     | 20 - 25    | 2              |
| Homemade pizza | 110              | 100                                 | -                     | 15 - 20    | 2              |
| Focaccia       | 110              | 100                                 | -                     | 20 - 30    | 2              |
| Vegetables     | 110              | 100                                 | -                     | 15 - 25    | 2              |
| Rice           | 110              | 100                                 | -                     | 15 - 26    | 2              |
| Pasta          | 110              | 100                                 | -                     | 15 - 27    | 2              |
| Meat           | 110              | 100                                 | -                     | 15 - 28    | 2              |

## Roasting

| Food                  | Temperature (°C) | Water in the cavity em-bossment (ml) | Preheating time (min) | Time (min)                             | Shelf position |
|-----------------------|------------------|--------------------------------------|-----------------------|--|----------------|
| Chicken               | 210              | 200                                  | -                     | 70 - 75                                | 2              |
| Half chicken          | 210              | 200                                  | -                     | 35 - 50                                | 2              |
| Roast pork            | 180              | 200                                  | -                     | 65 - 70                                | 2              |
| Roast beef 1 - 1,5 kg | 200              | 200                                  | -                     | 1. 50 - 55<br>2. 60 - 65<br>3. 65 - 70 | 2              |
| Roast turkey          | 200              | 200                                  | -                     | 70 - 85                                | 2              |

### 11.10 Tips on Roasting

Use heat-resistant ovenware.

Roast lean meat covered (you can use aluminium foil).

Roast large meat joints directly in the tray.

Put some water in the tray to prevent dripping fat from burning.

Turn the roast after 1/2 - 2/3 of the cooking time.

Roast meat and fish in large pieces (1 kg or more).

If level one is suggested put the food directly on the baking tray

Baste meat joints with their own juice several times during roasting.

### 11.11 Hot Air Roasting

#### Veal

| Food                         | Temperature (°C) | Time (min / kg) | Shelf position |
|------------------------------|------------------|-----------------|----------------|
| Fillet of beef <sup>1)</sup> | 160              | 60 - 70         | 2 - 3          |

<sup>1)</sup> Other. Can be browned off after roasting under the grill or with top / bottom heat at 250°C. If you are using a meat probe, remove it before grilling.

#### Lamb

| Food                    | Temperature (°C) | Time (min / kg) | Shelf position |
|-------------------------|------------------|-----------------|----------------|
| Leg / shoulder / saddle | 160              | 80 - 100        | 2              |

#### Pork

| Food                     | Temperature (°C) | Time (min / kg) | Shelf position |
|--------------------------|------------------|-----------------|----------------|
| Roast pork <sup>1)</sup> | 175              | 60 - 70         | 2 - 3          |
| Pork loin <sup>1)</sup>  | 175              | 60              | 2 - 3          |

| Food         | Temperature (°C) | Time (min / kg) | Shelf position |
|--------------|------------------|-----------------|----------------|
| Neck fillets | 160              | 90 - 120        | 2 - 3          |
| Ham          | 150              | 60 - 100        | 1 - 2          |

1) Other. Can be browned off after roasting under the grill or with top / bottom heat at 250°C. If you are using a meat probe, remove it before grilling.

### Poultry

| Food                             | Temperature (°C) | Time (min / kg)      | Shelf position |
|----------------------------------|------------------|----------------------|----------------|
| Chicken, parted                  | 180              | 55 - 65              | 2 - 3          |
| Duck <sup>1)</sup>               | 150              | 55 - 65              | 2 - 3          |
| Duck slow roasting <sup>1)</sup> | 130              | total around 5 hours | 2 - 3          |
| Roast turkey, stuffed            | 150              | 50 - 60              | 1 - 2          |
| Turkey breast                    | 175              | 70 - 80              | 2 - 3          |

1) Other. Can be browned off after roasting under the grill or with top / bottom heat at 250°C. If you are using a meat probe, remove it before grilling.

## 11.12 Conventional Roasting

### Veal

| Food                         | Temperature (°C) | Time (min / kg) | Shelf position |
|------------------------------|------------------|-----------------|----------------|
| Fillet of beef <sup>1)</sup> | 180              | 60 - 70         | 2 - 3          |

1) Other. Can be browned off after roasting under the grill or with top / bottom heat at 250°C. If you are using a meat probe, remove it before grilling.

### Lamb

| Food                 | Temperature (°C) | Time (min / kg) | Shelf position |
|----------------------|------------------|-----------------|----------------|
| Leg / shoulder / rib | 180              | 80 - 100        | 2              |

### Pork

| Food                     | Temperature (°C) | Time (min / kg) | Shelf position |
|--------------------------|------------------|-----------------|----------------|
| Roast pork <sup>1)</sup> | 200              | 60 - 70         | 3              |
| Pork loin <sup>1)</sup>  | 200              | 60              | 3              |
| Neck fillets             | 180              | 90 - 120        | 2 - 3          |

| Food | Temperature (°C) | Time (min / kg) | Shelf position |
|------|------------------|-----------------|----------------|
| Ham  | 160              | 60 - 100        | 1 - 2          |

1) Other. Can be browned off after roasting under the grill or with top / bottom heat at 250°C. If you are using a meat probe, remove it before grilling.

### Poultry

| Food                             | Temperature (°C) | Time (min / kg)      | Shelf position |
|----------------------------------|------------------|----------------------|----------------|
| Chicken, parted                  | 200              | 55 - 65              | 2 - 3          |
| Duck <sup>1)</sup>               | 160              | 55 - 65              | 2 - 3          |
| Duck slow roasting <sup>1)</sup> | 130              | total around 5 hours | 2 - 3          |
| Roast turkey, stuffed            | 160              | 50 - 60              | 1 - 2          |
| Turkey breast                    | 200              | 70 - 80              | 2 - 3          |

1) Other. Can be browned off after roasting under the grill or with top / bottom heat at 250°C. If you are using a meat probe, remove it before grilling.

## 11.13 Core temperature sensor table

### Beef

| Food                  | Food core temperature (°C) | Shelf position |
|-----------------------|----------------------------|----------------|
| Roast beef            | 55 - 65                    | 2 - 3          |
| Rump steak - browning | 55 - 65                    | 2 - 3          |
| Rump steak - roasting | 55 - 65                    | 2 - 3          |
| Roast beef            | 75 - 80                    | 1 - 2          |

### Veal

| Food           | Food core temperature (°C) | Shelf position |
|----------------|----------------------------|----------------|
| Fillet of beef | 65                         | 2 - 3          |

### Lamb

| Food                    | Food core temperature (°C) | Shelf position |
|-------------------------|----------------------------|----------------|
| Leg / shoulder / saddle | 90                         | 2              |

### Pork

| Food         | Food core temperature (°C) | Shelf position |
|--------------|----------------------------|----------------|
| Roast pork   | 80                         | 2 - 3          |
| Neck fillets | 75 - 80                    | 2 - 3          |



| Food | Food core temperature (°C) | Shelf position |
|------|----------------------------|----------------|
| Ham  | 70 - 75                    | 1 - 2          |

## Poultry

| Food          | Food core temperature (°C) | Shelf position |
|---------------|----------------------------|----------------|
| Turkey breast | 75 - 80                    | 2 - 3          |

## 11.14 Grilling in general

### **WARNING!**

Always grill with the oven door closed.

- **Always grill with the maximum temperature setting.**
- Set the shelf into the shelf position as recommended in the grilling table.
- If the first shelf position is recommended put the food directly on the baking tray.
- Always place the deep pan to collect fat on the first shelf position.

- Grill only flat pieces of meat or fish.

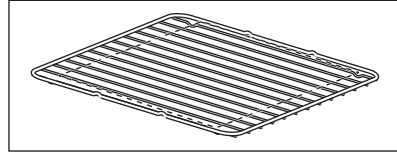

The grilling area is set in centre of the shelf.

## 11.15 AirFry

### Bakery products

| Food                | Quantity      | Temperature (°C) | Time (min) | Shelf position |
|---------------------|---------------|------------------|------------|----------------|
| Croissant, frozen   | approx. 350 g | 180 - 220        | 15 - 30    | 3              |
| Puff pastry, frozen | approx. 400 g | 180 - 220        | 15 - 35    | 3              |
| Puff pastry, fresh  | approx. 300 g | 180 - 220        | 15 - 35    | 3              |
| Pizza, frozen       | approx. 340 g | 180 - 220        | 20 - 35    | 3              |

### Potato products

| Food                       | Quantity      | Temperature (°C) | Time (min) | Shelf position |
|----------------------------|---------------|------------------|------------|----------------|
| French Fries, frozen       | approx. 650 g | 180 - 220        | 20 - 30    | 3              |
| French Fries thick, frozen | approx. 600 g | 180 - 220        | 20 - 30    | 3              |
| Potato wedges, frozen      | approx. 650 g | 180 - 220        | 15 - 25    | 3              |
| Croquettes                 | approx. 450 g | 180 - 220        | 15 - 30    | 3              |

## Fresh vegetables

| Food                                 | Quantity      | Temperature (°C) | Time (min) | Shelf position |
|--------------------------------------|---------------|------------------|------------|----------------|
| Zucchini slices, fresh <sup>1)</sup> | approx. 500 g | 180 - 220        | 25 - 35    | 3              |

<sup>1)</sup> add 1 teaspoon of olive oil to avoid sticking

## Other

| Food                            | Quantity      | Temperature (°C) | Time (min) | Shelf position |
|---------------------------------|---------------|------------------|------------|----------------|
| Escalopes, frozen               | approx. 300 g | 180 - 220        | 15 - 25    | 3              |
| Shrimps in baking dough, frozen | approx. 200 g | 180 - 220        | 15 - 25    | 3              |
| Calamari rings, frozen          | approx. 250 g | 180 - 220        | 15 - 25    | 3              |
| Chicken nuggets, frozen         | approx. 300 g | 180 - 220        | 15 - 25    | 3              |
| Fish fingers, frozen            | approx. 500 g | 180 - 220        | 15 - 25    | 3              |

## 11.16 Information for test institutes

| Food   | Function     | Temperature (°C) | Time (min) | Accessories         | Shelf position |
|--|--------------|------------------|------------|---------------------|----------------|
| Small cakes (20 small cakes per tray)                          | Conventional | 170              | 20 - 30    | Tray                | 4              |
| Small cakes (20 small cakes per tray) <sup>1)</sup>            | Hot Air      | 150              | 20 - 30    | Tray                | 2              |
| Small cakes (20 small cakes per tray) <sup>1)</sup>            | Hot Air      | 150              | 25 - 35    | Tray / Dripping Pan | 1 + 4          |
| Apple pie, 2 tins (ø 20 cm) on the grid, diagonally shifted    | Conventional | 180              | 70 - 90    | Grid                | 1              |
| Apple pie, 2 tins (ø 20 cm) on the grid, diagonally shifted    | Hot Air      | 160              | 70 - 90    | Grid                | 2              |
| Apple pie, 2 tins (ø 20 cm) on the grid, diagonally shifted    | Pie / Pizza  | 160              | 60 - 80    | Grid                | 2              |
| Fatless sponge cake, 1 tin (ø 26 cm) on the grid               | Conventional | 170              | 30 - 40    | Grid                | 3              |
| Fatless sponge cake, 1 tin (ø 26 cm) on the grid               | Hot Air      | 150              | 35 - 45    | Grid                | 2              |
| Fatless sponge cake, 1 tin (ø 26 cm) on the grid <sup>1)</sup> | Hot Air      | 160              | 25 - 35    | Grid                | 1 + 4          |
| Shortbread/Pastry strip  | Hot Air      | 140              | 20 - 35    | Tray                | 3              |
| Shortbread/Pastry strip  | Hot Air      | 140              | 20 - 30    | Tray                | 1 + 4          |

| Food                    | Function     | Temperature (°C) | Time (min)                                  | Accessories         | Shelf position |
|-------------------------|--------------|------------------|---|---------------------|----------------|
| Shortbread/Pastry strip | Conventional | 160              | 20 - 35                                     | Tray                | 3              |
| Toast <sup>1)</sup>     | (Max) Grill  | Max              | 1 - 5                                       | Grid                | 4              |
| Beef burger             | Grill        | Max              | 15 - 20 first side.<br>10 - 15 second side. | Grid / Dripping pan | 4 + 1          |

1) Preheat the oven for 10 minutes.

## 12. OVEN - CARE AND CLEANING

### WARNING!

Refer to Safety chapters.

### 12.1 Notes on cleaning



#### Cleaning Agents

Clean the front of the appliance only with a microfibre cloth with warm water and a mild detergent.

Use a cleaning solution to clean metal surfaces.

Clean stains with a mild detergent. Do not apply it on the catalytic surfaces.



#### Everyday Use

Clean the cavity after each use. Fat accumulation or other residue may cause fire.

Do not store the food in the appliance for longer than 20 minutes. Dry the cavity only with a microfibre cloth after each use.



#### Accessories

Clean all accessories after each use and let them dry. Use only a microfibre cloth with warm water and a mild detergent. Do not clean the accessories in a dishwasher (except from AirFry tray).

Do not clean the non-stick accessories and AirFry tray using abrasive cleaner or sharp-edged objects.

### 12.2 Cleaning the AirFry tray

- Put the AirFry tray on the baking tray.
- Pour hot water with detergent and let it soak.
- Clean the AirFry tray with a sponge or use a brush to remove scraps.

Cleaning in the dishwasher is also possible.

### 12.3 Stainless steel or aluminium ovens

Clean the oven door with a damp cloth or sponge only. Dry it with a soft cloth.

Do not use steel wool, acids or abrasive materials as they can damage the oven surface. Clean the oven control panel with the same precautions.

## 12.4 Catalytic cleaning

### ⚠ CAUTION!

Do not clean the catalytic surface with oven sprays, soap or other cleaning agents. It will damage the catalytic surface.

### ⚠ CAUTION!

Always turn the oven light on while using the catalytic cleaning (if applicable).

### ⚠ WARNING!

Keep children away when you clean the oven at a high temperature. The oven surface becomes very hot and there is a risk of burns.



Spots or discolouration of the catalytic surface have no effect on catalytic properties.



Before activating the catalytic cleaning remove all the accessories from the oven.

The walls with catalytic coating are self-cleaning. They absorb fat which collects on the walls while the appliance operates.

To support the self-cleaning procedure, heat the empty oven on a regular basis.

1. Clean the oven floor with warm water and washing-up liquid, then dry it.
2. Set the  function.
3. Set the oven temperature to 250 °C and let the oven operate for 1 hour.
4. When the appliance is cool, clean it with a soft and moist sponge.

## 12.5 Cleaning the cavity embossment

The cleaning procedure removes limestone residue from the cavity embossment after cooking with steam.



For the function: Steam Bake we recommend to do the cleaning procedure at least every 5 - 10 cooking cycles.

1. Put 250 ml of white vinegar into the cavity embossment at the bottom of the oven. Use maximum 6% vinegar without any additives.
2. Let the vinegar dissolve the residual limestone at the ambient temperature for 30 minutes.
3. Clean the cavity with warm water and a soft cloth.

## 12.6 Removing the shelf supports

To clean the oven, remove the shelf supports.

1. Pull the front of the shelf support away from the side wall.

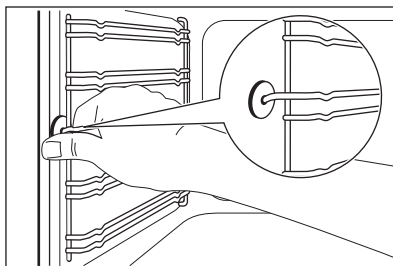

2. Pull the rear end of the shelf support away from the side wall and remove it.

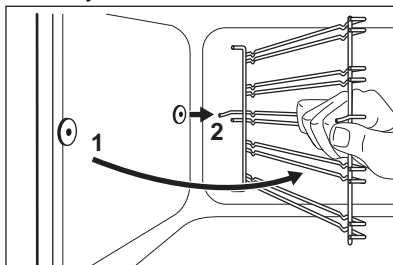

Install the shelf supports in the opposite sequence.

### ⚠ CAUTION!

Make sure that the longer fixing wire is in the front. The ends of the two wires must point to the rear. Incorrect installation can cause damage to the enamel.

## 12.7 Removing the oven door

To make the cleaning easier, remove the door.

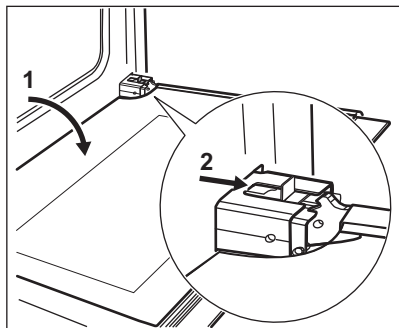

1. Open the door fully.
2. Move the slider until you hear a click.
3. Close the door until the slider locks.
4. Remove the door.  
To remove the door, pull the door outwards first from one side, and then the other.

When the cleaning procedure is completed, insert the oven door in the opposite sequence. Make sure that you hear a click when you insert the door. Use force if necessary.

## 12.8 Removing and cleaning the door glasses



The door glass in your product can be different in type and shape from the examples you see in the images. The number of glasses can also be different.

1. Hold the door trim B on the top edge of the door at the two sides and push inwards to release the clip seal.

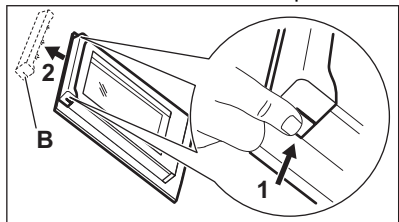

2. Pull the door trim to the front to remove it.

3. Hold the door glass panels on their top edge one by one and pull them upwards from the guide.

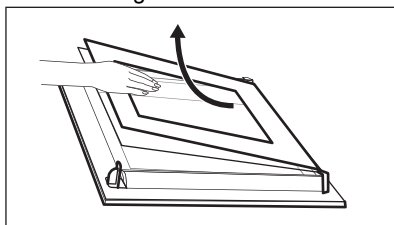

4. Clean the door glass panels.  
To install panels, do the same steps in reverse.

## 12.9 Replacing the lamp

### **WARNING!**

Risk of electric shock.  
The lamp can be hot.

1. Turn off the oven. Wait until the oven is cold.
2. Disconnect the oven from the mains.
3. Put a cloth on the bottom of the cavity.

### The back lamp



The lamp glass cover is at the back of the cavity.

1. Turn the lamp glass cover counterclockwise to remove it.
2. Clean the glass cover.
3. Replace the oven lamp with a suitable 300 °C heat-resistant oven lamp.  
Use the same oven lamp type.
4. Install the glass cover.

### The side lamp

Find the lamp glass cover at the left side of the cavity.

1. Remove the left shelf support to get access to the lamp.
2. Use a narrow, blunt object (e.g. a teaspoon) to remove the glass cover.

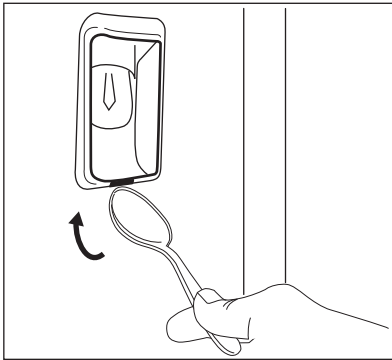

3. Clean the glass cover.
4. Replace the lamp with a suitable 300 °C heat-resistant lamp.
5. Install the glass cover.
6. Install the left shelf support.

### 12.10 The drawer

#### **⚠ WARNING!**

Do not put food inside the drawer.

#### **⚠ WARNING!**

Do not keep flammable items such as cleaning materials, plastic bags, oven gloves, paper, cleaning products, aerosols, plastic items) in the drawer. When you use the oven, the drawer can become hot. There is a risk of fire.

The drawer below the oven can be removed for cleaning.

#### **Removing the drawer:**

1. Pull the drawer out until it stops.
2. Lift the drawer slightly, so that can be lifted upwards at an angle of the drawer guides.

To install the drawer, follow the procedure in reverse.





## 13. TROUBLESHOOTING

#### **⚠ WARNING!**

Refer to Safety chapters.

### 13.1 What to do if...

| Problem                                 | Possible cause   | Remedy  |
|---|--|---|
| You cannot activate the appliance.      | The appliance is not connected to an electrical supply or it is connected incorrectly. | Check if the appliance is correctly connected to the electrical supply.   |
| You cannot activate the appliance.      | The fuse is blown.   | Make sure that the fuse is the cause of the malfunction. If the fuse is blown again and again, contact a qualified electrician. |
| You cannot activate or operate the hob. | You touched 2 or more sensor fields at the same time.                                  | Touch only one sensor field.  |
| You cannot activate or operate the hob. | There is water or fat stains on the control panel.                                     | Clean the control panel.  |

| <b>Problem</b>   | <b>Possible cause</b>   | <b>Remedy</b>   |
|--|---|---|
| An acoustic signal sounds and the hob deactivates.<br>An acoustic signal sounds when the hob is deactivated. | You put something on one or more sensor fields.                                     | Remove the object from the sensor fields.   |
| Residual heat indicator does not come on.  | The zone is not hot because it operated only for a short time.                      | If the zone operated sufficiently long to be hot, speak to an Authorised Service Centre.            |
| Automatic Heat Up function does not operate.   | The zone is hot.  | Let the zone become sufficiently cool.  |
| Automatic Heat Up function does not operate.   | The highest heat setting is set.  | The highest heat setting has the same power as the function.  |
| The heat setting changes between two levels.   | Power management function operates.   | Refer to "Hob - Daily use" chapter.   |
| The sensor fields become hot.  | The cookware is too large or you put it too near to the controls.                   | Put large cookware on the rear zones if possible.   |
| There is no signal when you touch the panel sensor fields.   | The signals are deactivated.  | Activate the signals. Refer to "Hob - Daily use" chapter.   |
|  comes on the hob display.   | Automatic Switch Off operates.  | Deactivate the hob and activate it again.   |
|  comes on the hob display.   | The Child Safety Device or the Lock function operates.                              | Refer to "Hob - Daily use" chapter.   |
|  comes on the hob display.   | There is no cookware on the zone.   | Put cookware on the zone.   |
|  comes on the hob display.   | The cookware is incorrect.  | Use the correct cookware. Refer to "Hob - Hints and tips" chapter.                                  |
|  comes on the hob display.   | The diameter of the bottom of the cookware is too small for the zone.               | Use cookware with correct dimensions. Refer to "Hob - Hints and tips" chapter.                      |
| The oven does not heat up.   | The oven is deactivated.  | Activate the oven.  |
| The oven does not heat up.   | The clock is not set.   | Set the clock.  |
| The oven does not heat up.   | The necessary settings are not set.   | Make sure that the settings are correct.  |
| The lamp does not operate.   | The lamp is defective.  | Replace the lamp.   |
| The display shows "12.00".   | There was a power cut.  | Reset the clock.  |
| The display shows F11.   | The plug of the core temperature sensor is not correctly installed into the socket. | Put the plug of the core temperature sensor as far as possible into the socket.                     |
| Steam and condensation settle on the food and in the cavity of the oven.                                     | You left the dish in the oven for too long.   | Do not leave the dishes in the oven for longer than 15 - 20 minutes after the cooking process ends. |
| There is no good cooking performance using the Steam Bake function.  | You did not fill the cavity embossment with water.                                  | Refer to "Activating the Steam Bake function".  |

| Problem   | Possible cause                                    | Remedy  |
|---|---|---|
| The water in the cavity embossment does not boil. | The temperature is too low.                       | Set the temperature at least to 110°C. Refer to "Oven - Hints and tips" chapter.  |
| The water comes out of the cavity embossment.     | There is too much water in the cavity embossment. | Deactivate the oven and make sure that the appliance is cold. Wipe the water with a cloth or sponge. Add the correct amount of water to the cavity embossment. Refer to "Activating the Steam Bake function". |

## 13.2 Service data

If you cannot find a solution to the problem yourself, contact your dealer or an Authorised Service Centre.

The necessary data for the service centre is on the rating plate. The rating plate is on the front frame of the appliance cavity. Do not remove the rating plate from the appliance cavity.

### We recommend that you write the data here:

Model (MOD.) .....

Product number (PNC) .....

Serial number (S.N.) .....

## 14. ENERGY EFFICIENCY

### 14.1 Product Information according to EU Ecodesign Regulations for hob

|  |                                |             |
|--|--------------------------------|-------------|
| Model identification   | LKI66441NK                     |             |
| Type of hob  | Hob inside Freestanding Cooker |             |
| Number of cooking zones  | 4                              |             |
| Heating technology   | Induction                      |             |
| Diameter of circular cooking zones (Ø)   | Left front                     | 21.0 cm     |
|  | Left rear                      | 14.0 cm     |
|  | Right front                    | 18.0 cm     |
|  | Right rear                     | 18.0 cm     |
| Energy consumption per cooking zone (EC electric cooking)  | Left front                     | 178.0 Wh/kg |
|  | Left rear                      | 179.0 Wh/kg |
|  | Right front                    | 181.0 Wh/kg |
|  | Right rear                     | 181.0 Wh/kg |
| Energy consumption of the hob (EC electric hob)  | 179.8 Wh/kg                    |             |
| IEC/EN 60350-2 - Household electric cooking appliances - Part 2: Hobs - Methods for measuring performance. |                                |             |



## 14.2 Hob - Energy saving

You can save energy during everyday cooking if you follow the hints below.

- When you heat up water, use only the amount you need.
- If it is possible, always put the lids on the cookware.

- Put the cookware directly in the centre of the cooking zone.
- Use the residual heat to keep the food warm or to melt it.

## 14.3 Product Information and Product Information Sheet according to EU Ecodesign and Energy Labelling Regulations for ovens

|  |                                 |
|--|---------------------------------|
| Supplier's name  | Electrolux                      |
| Model identification                                       | LKI66441NK 947941521            |
| Energy Efficiency Index                                    | 95.3                            |
| Energy efficiency class                                    | A                               |
| Energy consumption with a standard load, conventional mode | 0.95 kWh/cycle                  |
| Energy consumption with a standard load, fan-forced mode   | 0.82 kWh/cycle                  |
| Number of cavities   | 1                               |
| Heat source  | Electricity                     |
| Volume   | 73 l                            |
| Type of oven   | Oven inside Freestanding Cooker |
| Mass   | 62.2 kg                         |

IEC/EN 60350-1 - Household electric cooking appliances - Part 1: Ranges, ovens, steam ovens and grills - Methods for measuring performance.

## 14.4 Oven - Energy saving



The appliance has features which help you save energy during everyday cooking.

Make sure that the appliance door is closed when the appliance operates. Do not open the appliance door too often during cooking. Keep the door gasket clean and make sure it is well fixed in its position.

Use metal cookware to improve energy saving.

When possible, do not preheat the appliance before cooking.

Keep breaks between baking as short as possible when you prepare a few dishes at one time.

### Cooking with fan

When possible, use the cooking functions with fan to save energy.

### Residual heat

When the cooking duration is longer than 30 min, reduce the appliance temperature to minimum 3 - 10 min before the end of cooking. The residual heat inside the appliance will continue to cook.

Use the residual heat to warm up other dishes.



### Keep food warm

Choose the lowest possible temperature setting to use residual heat and keep a meal warm.

### Moist Fan Baking

Function designed to save energy during cooking.

## 15. ENVIRONMENTAL CONCERNS

Recycle materials with the symbol . Put the packaging in relevant containers to recycle it. Help protect the environment and human health by recycling waste of electrical and electronic appliances. Do not dispose of appliances marked with the symbol  with

the household waste. Return the product to your local recycling facility or contact your municipal office.

Electrolux Appliances AB - Contact Address:  
Al. Powstancow Slaskich 26, 30-570 Krakow,  
Poland



**electrolux.com**

867363872-A-202023



**CE**